



AIDE AU MONTAGE

MOBILIER BOIS

Pour plus d'informations, contactez-nous : 02 43 07 85 29 ou commercial@tilt-equipement.com

RECOMMANDATIONS

À réception du colis, vérifiez :

- 1 - La référence de votre module
- 2 - Le nombre de colis à réceptionner par module

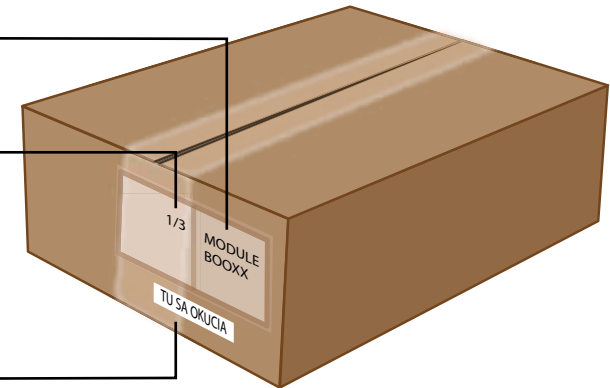

Cette étiquette identifie le colis contenant la visserie pour l'ensemble du meuble.

OUTILS NÉCESSAIRES

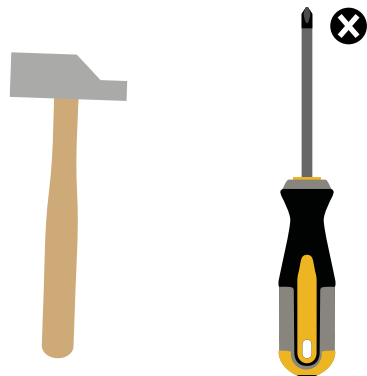

Protégez votre mobilier en effectuant le montage sur un tapis ou un carton

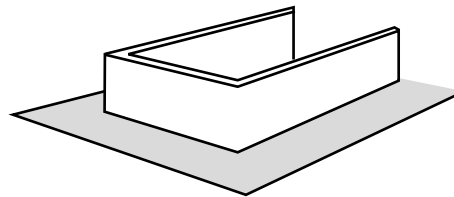

Pour toute information, n'hésitez pas à nous contacter :

02 43 07 85 29

B0001

MODULE ANGLE BAS

REF.	Dimension (HxLxP) en mm
B0001	800 x 600 x 600

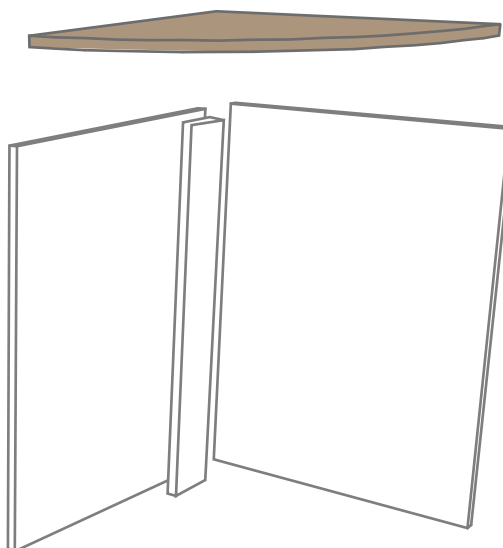

NOMBRE DE COLIS

Plusieurs colis possibles référencés
comme suit : 1/2 et 2/2 pour 2 colis

CONTENU DES COLIS

- Plan de travail d'angle x1
- Côtés x2
- Planche d'angle x1
- Sachet de visserie x1

VISSERIE



▶ Pied réglable



▶ Écrou à vis



▶ Excentrique



▶ Goujon



▶ Vis d'assemblage



▶ Vis à bois



▶ Cheville

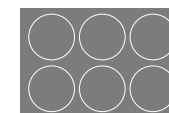

▶ Pastille

B0001 - MODULE ANGLE BAS

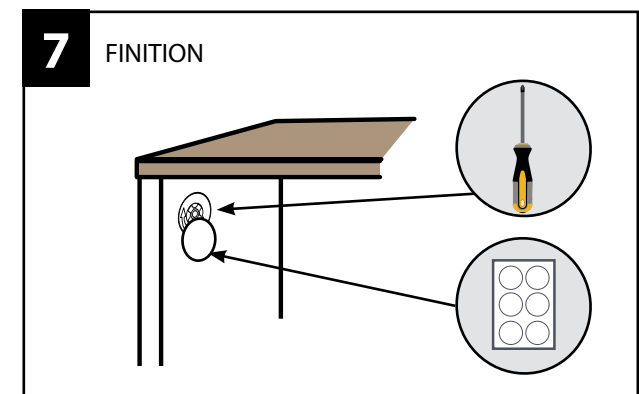
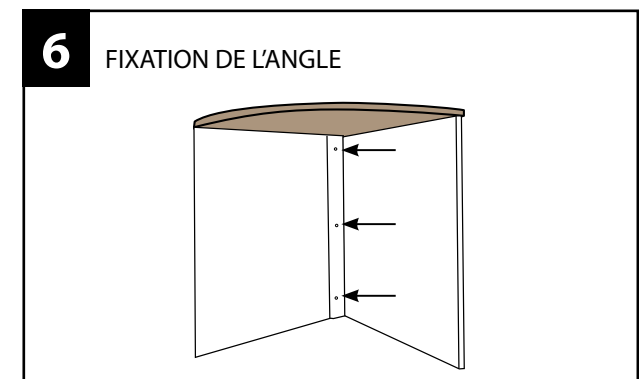
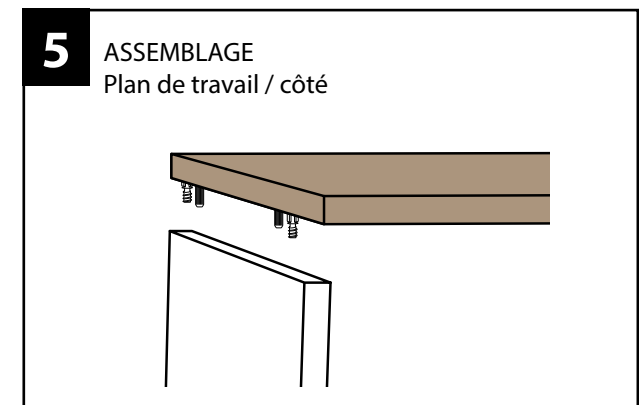
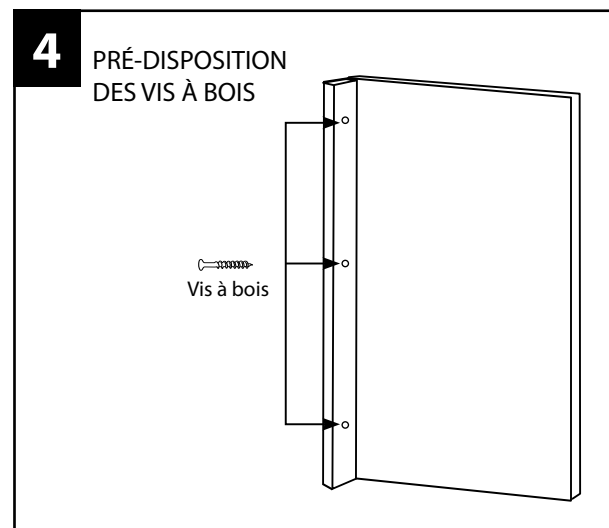
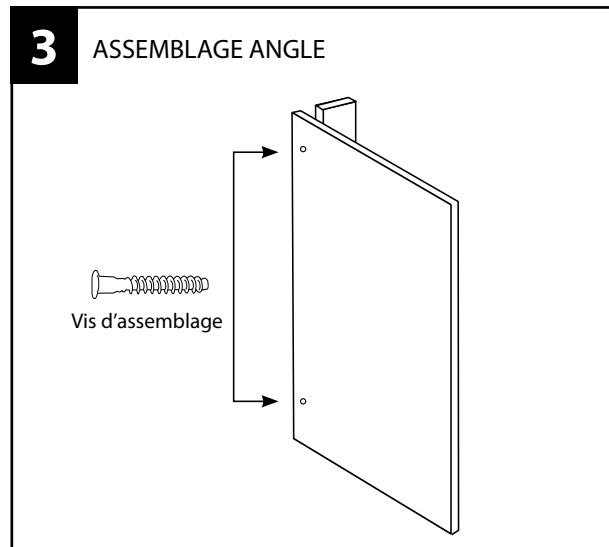
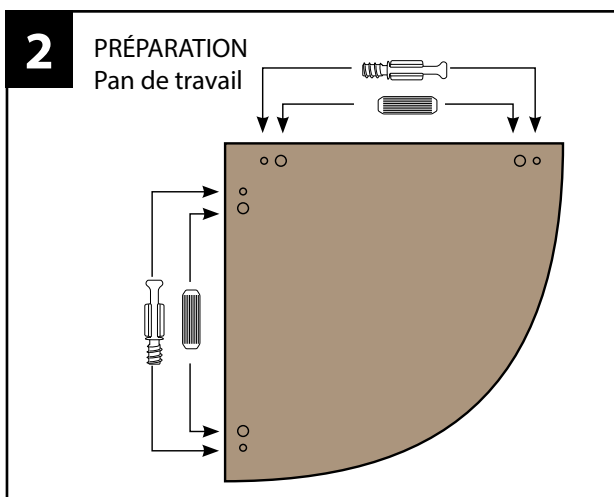
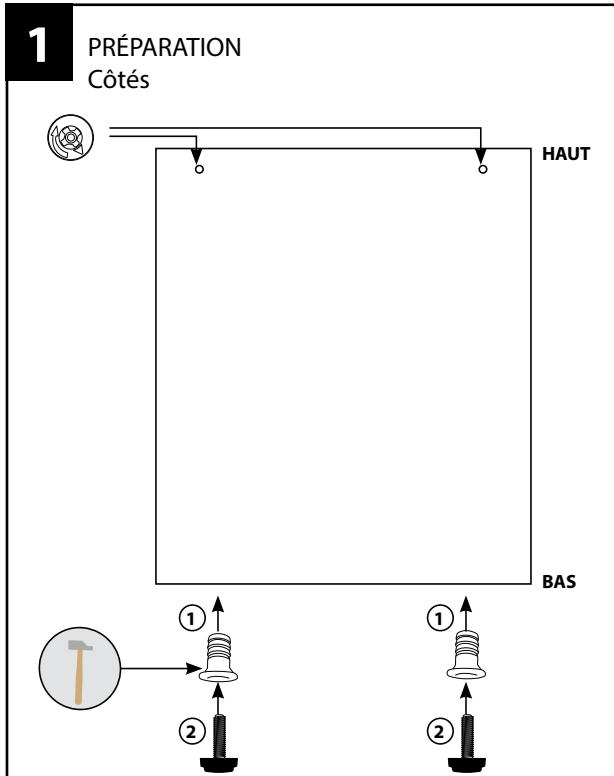
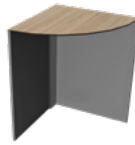

B0019 ou B0028

MODULE BUREAU BAS

REF.	Dimension (HxLxP) en mm
B0019	800 x 1200 x 600
B0028	800 x 800 x 600

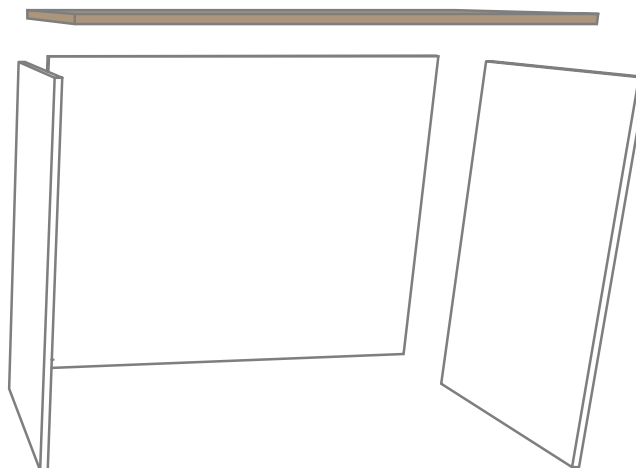

NOMBRE DE COLIS

Plusieurs colis possibles référencés comme suit : 1/2 et 2/2 pour 2 colis

CONTENU DES COLIS

- Plan de travail rectangulaire x1
- Côtés x2
- Fond x1
- Sachet de visserie x1

VISSERIE



▶ Pied réglable



▶ Écrou à vis



▶ Excentrique



▶ Goujon



▶ Cheville

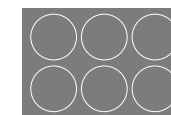

▶ Pastille

B0019 ou B0028 - MODULE BUREAU BAS



1 PRÉPARATION Côtés

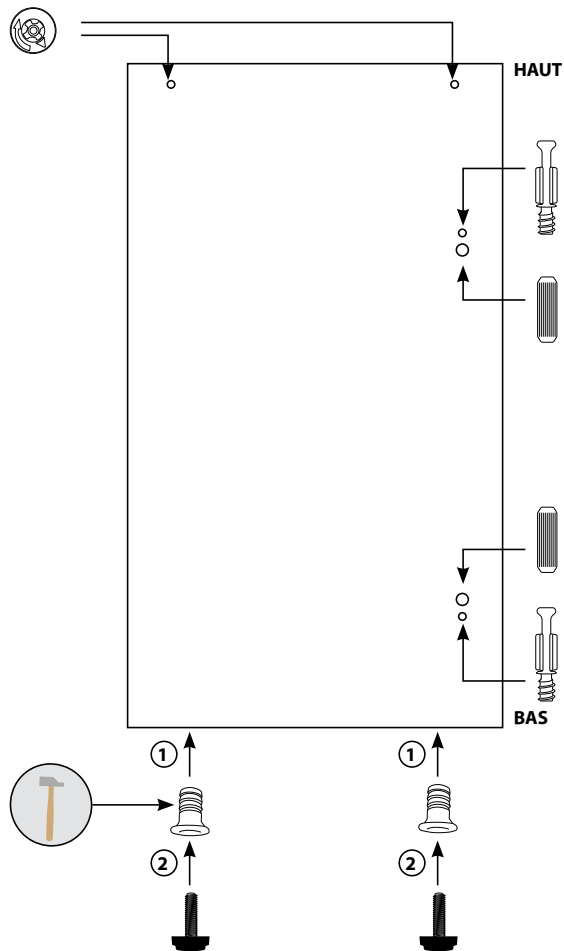

2 PRÉPARATION Pan de travail

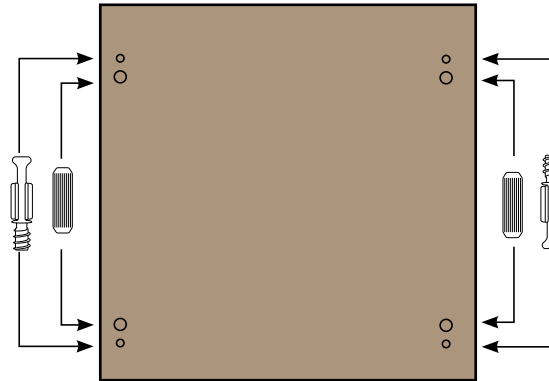

3 PRÉPARATION Fond

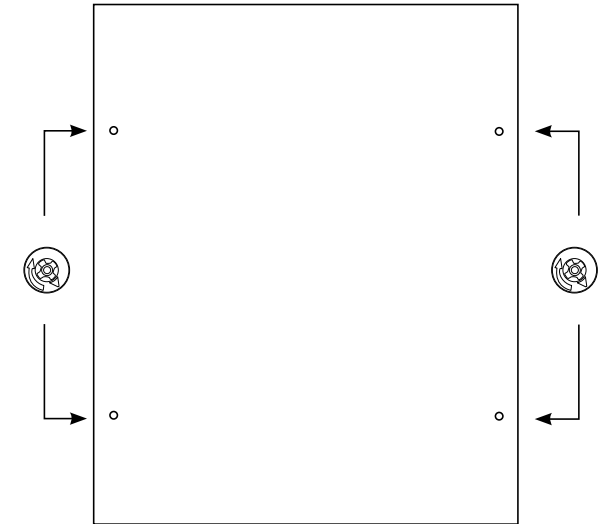

4 ASSEMBLAGE Côtés / Fond

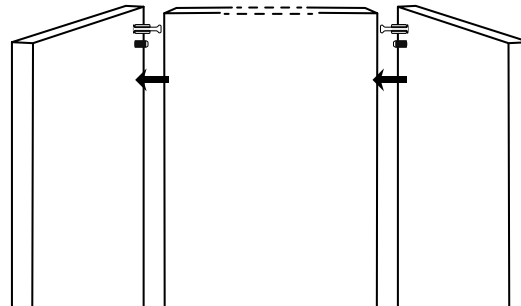

5 ASSEMBLAGE Plan de travail

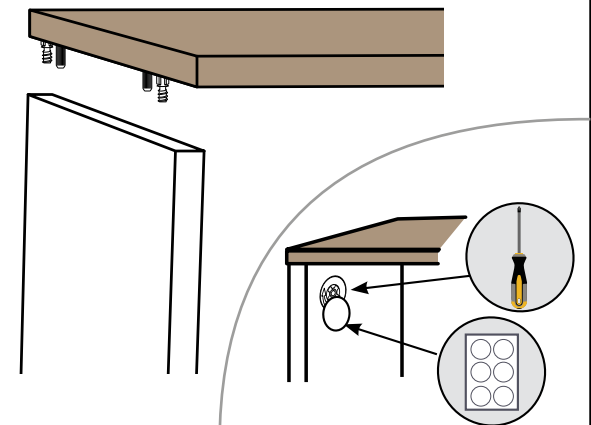

B0002 ou B0003

RANGEMENT BAS

REF.	Dimension (HxLxP) en mm
B0002	800 x 1000 x 600
B0003	800 x 600 x 600

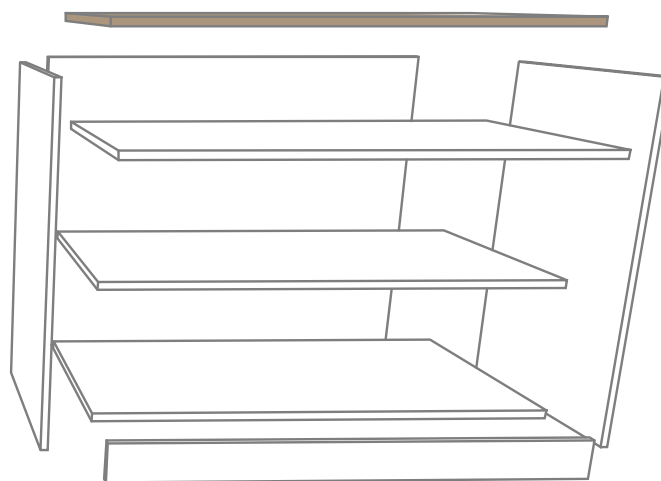

NOMBRE DE COLIS

Plusieurs colis possibles référencés comme suit : 1/2 et 2/2 pour 2 colis

CONTENU DES COLIS

- Plan de travail rectangulaire x1
- Côtés x2
- Étagères x3
- Plinthe x1
- Fond x1
- Sachet de visserie x1

VISSERIE



▶ Pied réglable



▶ Écrou à vis



▶ Goujon



▶ Excentrique



▶ Cheville

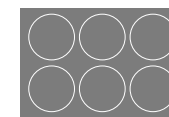

▶ Pastille



▶ Taquet

B0002 ou B0003 - RANGEMENT BAS



1 PRÉPARATION Côtés

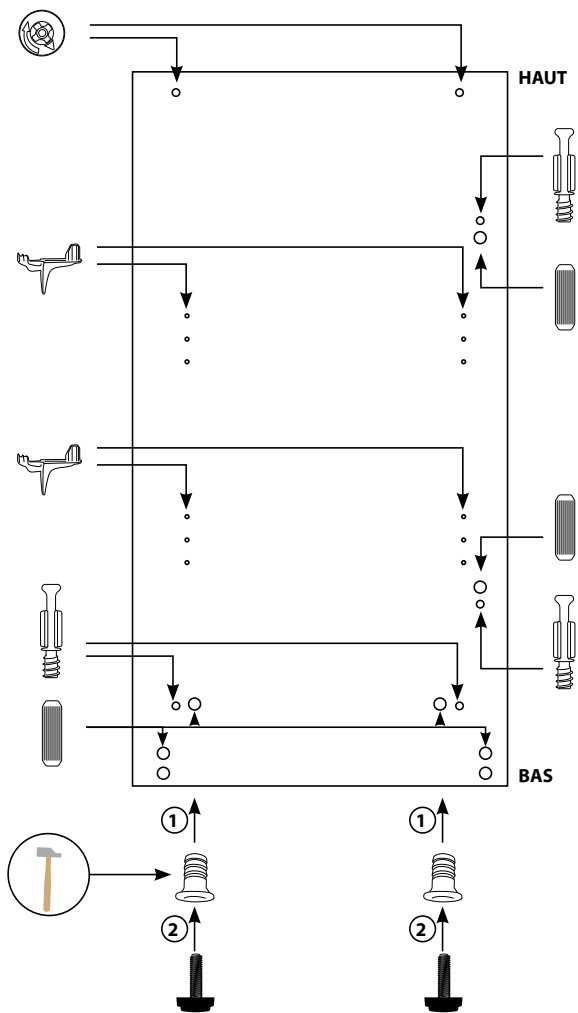

2 PRÉPARATION Pan de travail

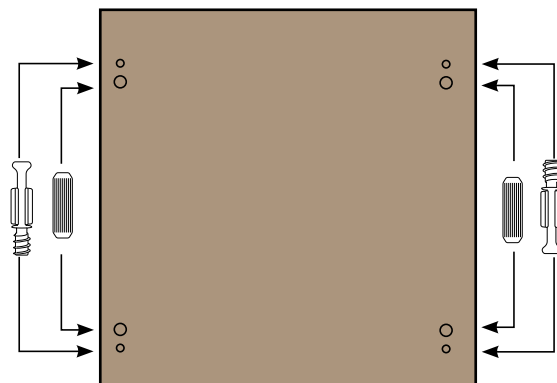

3 PRÉPARATION Fond

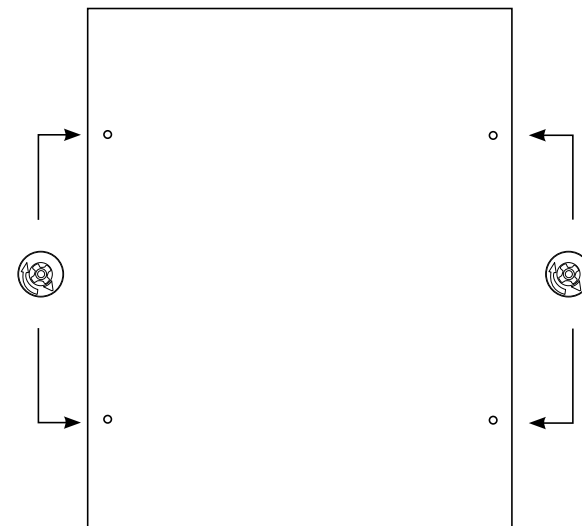

4 ASSEMBLAGE Côtés, plinthe, étagère du bas / Fond

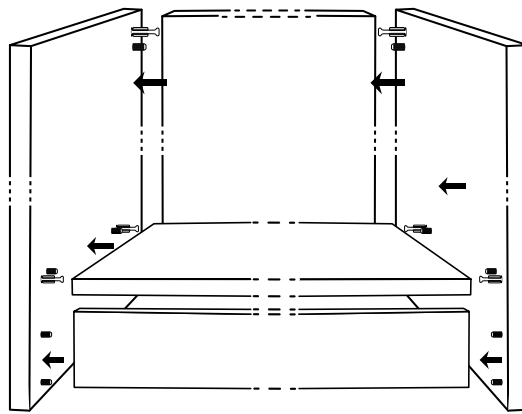

5 ASSEMBLAGE Plan de travail

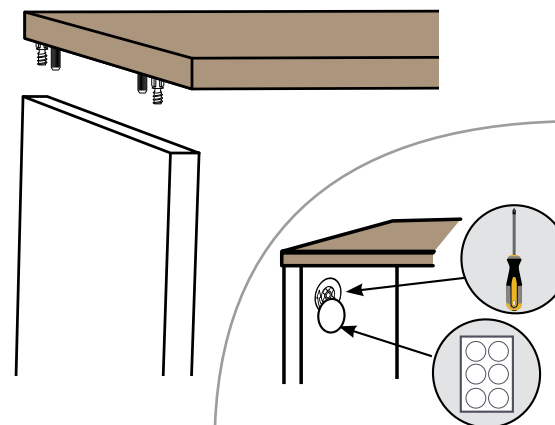

B0032

RANGEMENT HAUT

REF.	Dimension (HxLxP) en mm
B0032	1120 x 1000 x 600

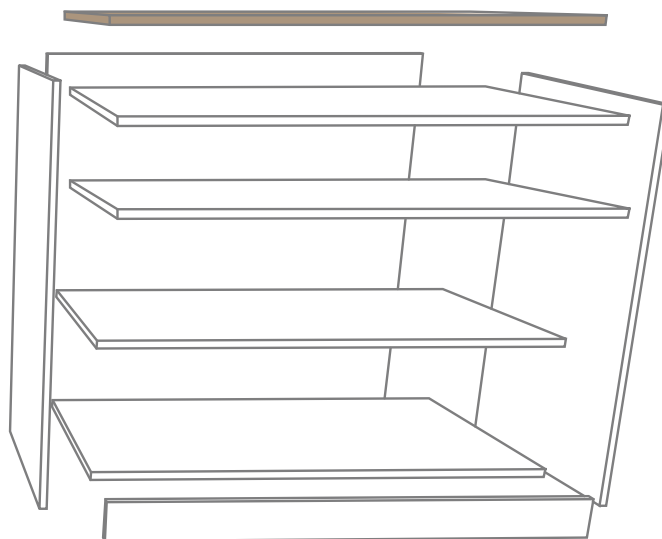

NOMBRE DE COLIS

Plusieurs colis possibles référencés
comme suit : 1/2 et 2/2 pour 2 colis

CONTENU DES COLIS

- Plan de travail rectangulaire x1
- Côtés x2
- Étagères x4
- Plinthe x1
- Fond x1
- Sachet de visserie x1

VISSERIE



▶ Pied réglable



▶ Écrou à vis



▶ Goujon



▶ Excentrique



▶ Cheville

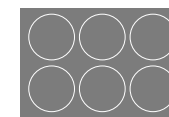

▶ Pastille



▶ Taquet

B0032 - RANGEMENT HAUT



1 PRÉPARATION Côtés

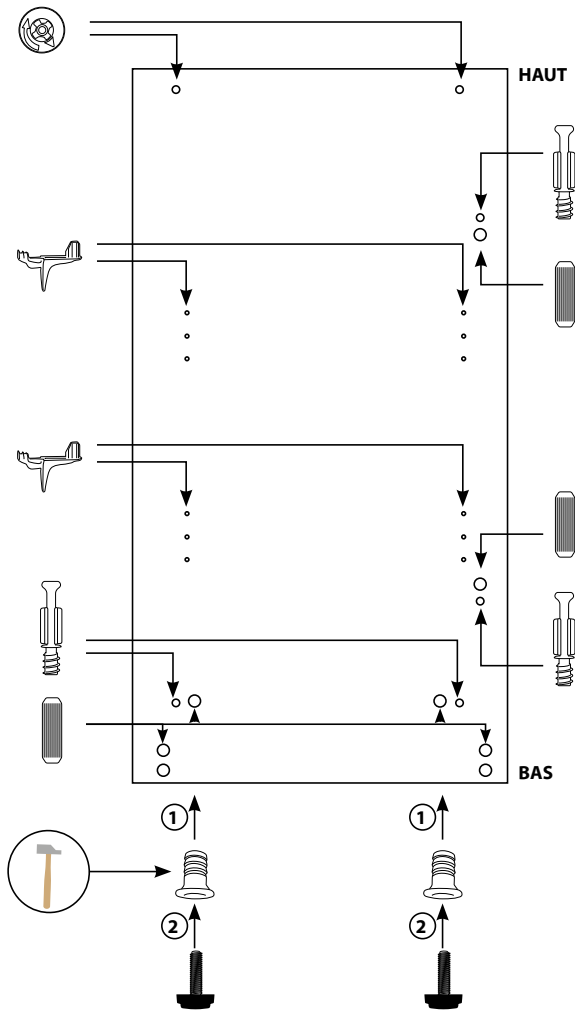

2 PRÉPARATION Pan de travail

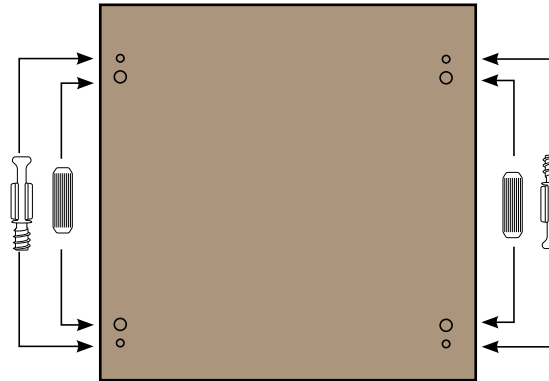

3 PRÉPARATION Fond

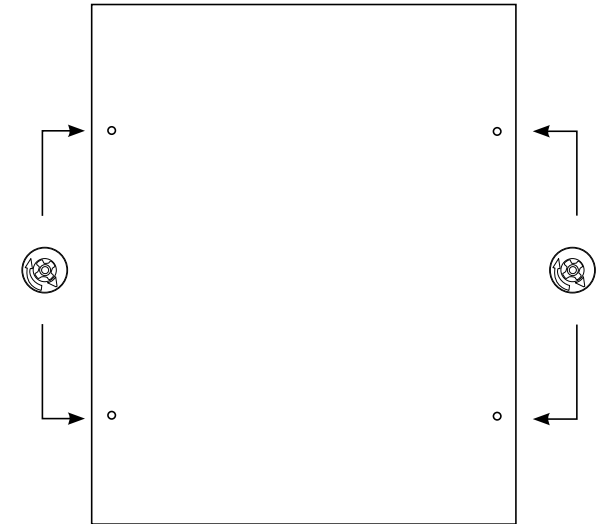

4 ASSEMBLAGE Côtés, plinthe, étagère du bas / Fond

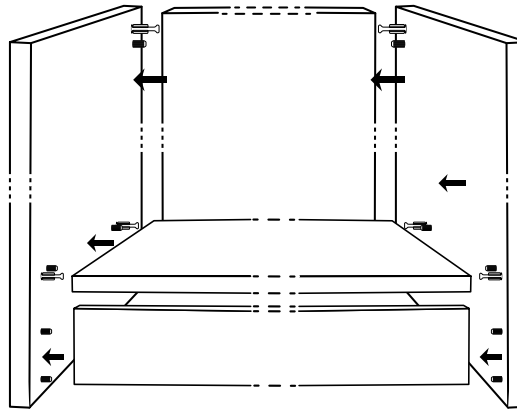

5 ASSEMBLAGE Plan de travail

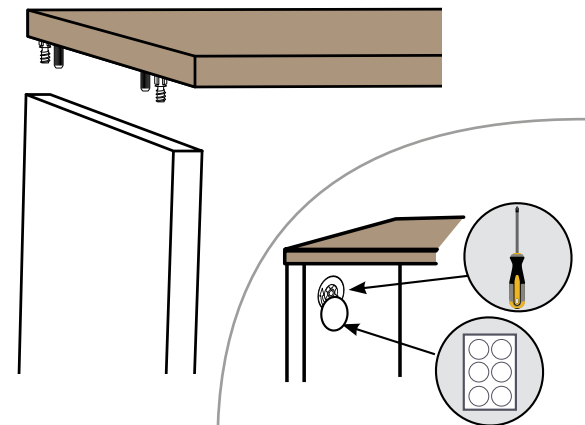

B0033

MODULE ANGLE HAUT

REF.	Dimension (HxLxP) en mm
B0033	1120 x 600 x 600

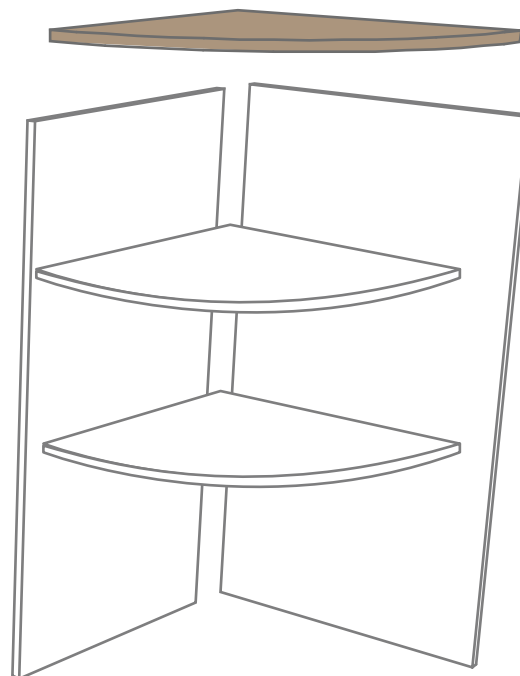

NOMBRE DE COLIS

Plusieurs colis possibles référencés
comme suit : 1/2 et 2/2 pour 2 colis

CONTENU DES COLIS

- Plan de travail rectangulaire x1
- Côtés x2
- Étagères x2
- Sachet de visserie x1

VISSERIE



▶ Pied réglable



▶ Écrou à vis



▶ Excentrique



▶ Goujon



▶ Cheville

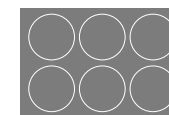

▶ Pastille

B0033 - MODULE ANGLE HAUT



1 PRÉPARATION Côtés

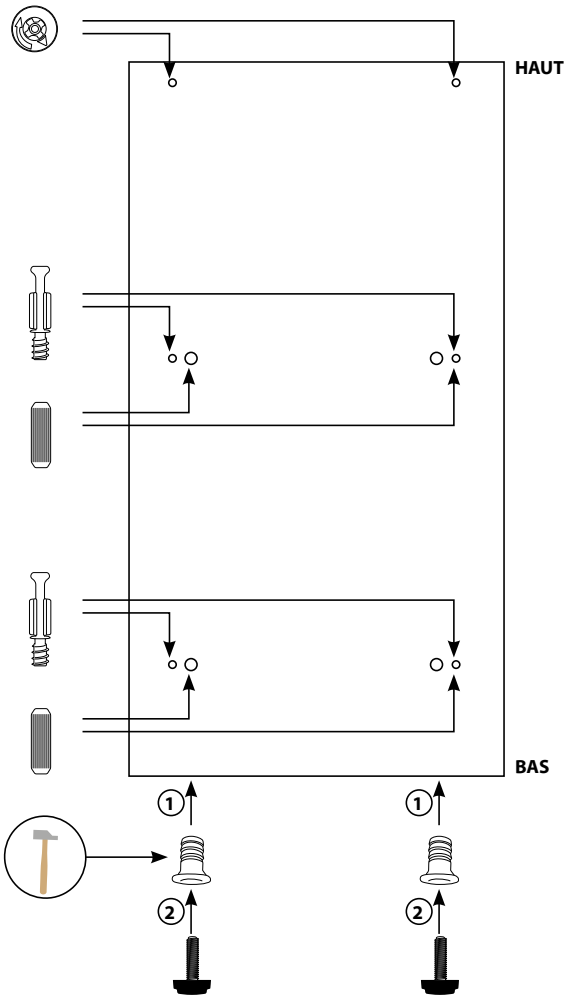

2 PRÉPARATION Pan de travail

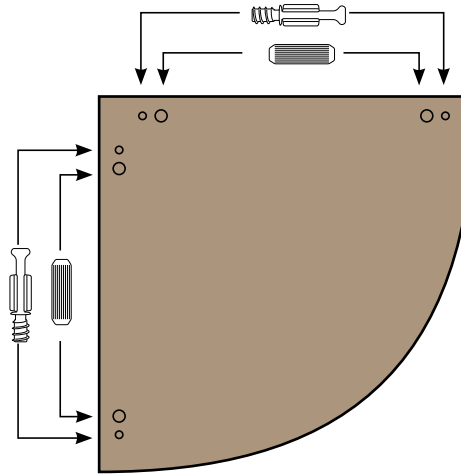

3 PRÉPARATION Étagère

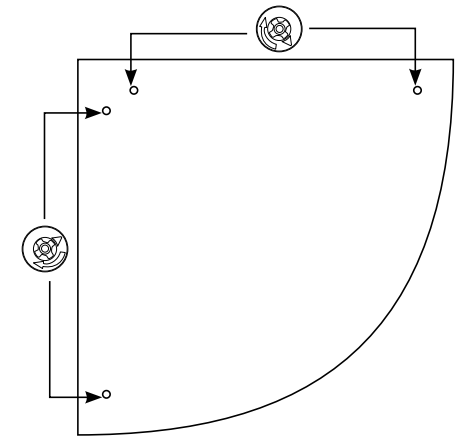

4 ASSEMBLAGE Côtés / Étagères

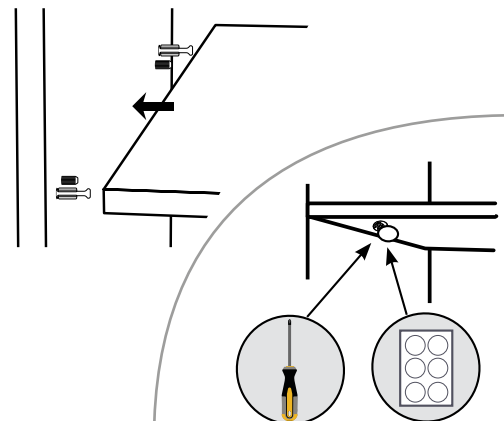

5 ASSEMBLAGE Plan de travail

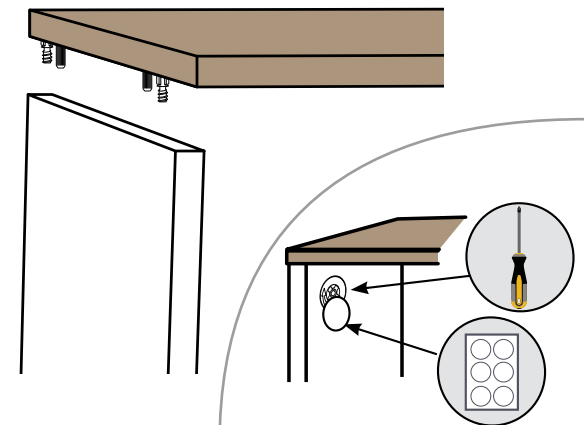

B0005

MODULE INFORMATIQUE AVEC PORTES

REF.	Dimension (HxLxP) en mm
B0005	1120 x 800 x 600









NOMBRE DE COLIS

Plusieurs colis possibles référencés
comme suit : 1/2 et 2/2 pour 2 colis

CONTENU DES COLIS

- Plan de travail rectangulaire
- Côtés x2
- Fond x1
- Étagères x3
- Support coulissant pour clavier x1
- Portes x2
- Plinthe x1
- Glissières x2
- Poignées x2
- Sachet x1

VISSERIE

- | | |
|--|--|
| 
▶ Pied réglable | 
▶ Écrou à vis |
| 
▶ Excentrique | 
▶ Goujon |
| 
▶ Cheville | 
▶ Pastille |
| 
▶ Taquet | 
▶ Fixation portes |
| 
▶ Sachet vis | |
| 
▶ Glissière | |

B0005 - MODULE INFORMATIQUE AVEC PORTES



1 PRÉPARATION Côtés

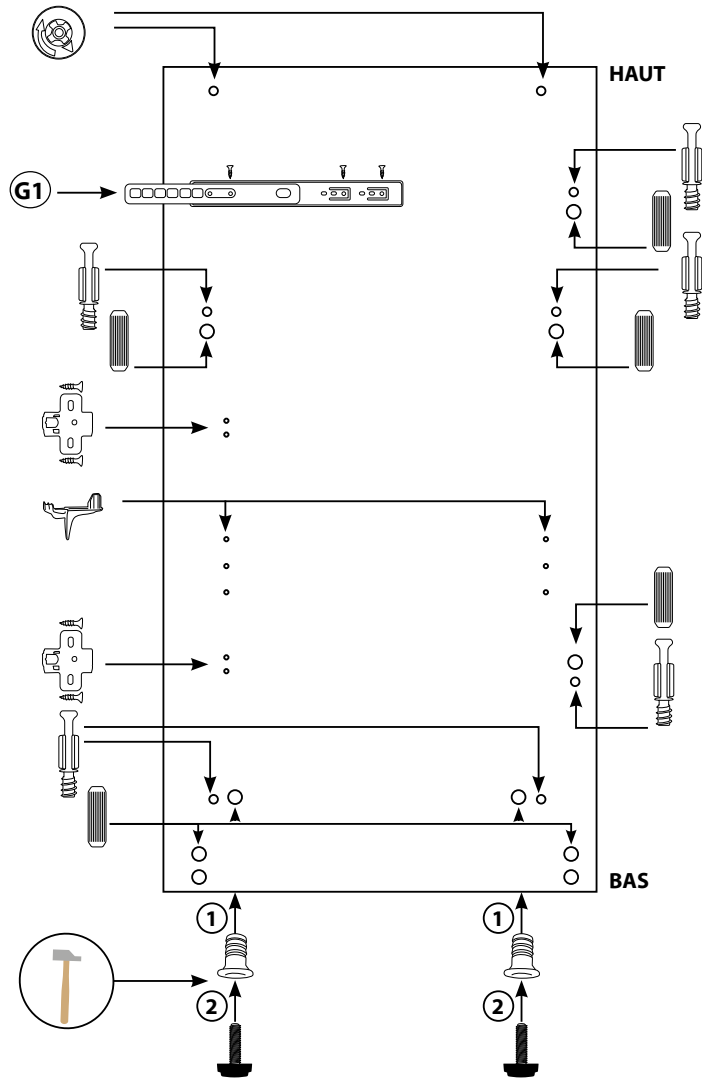

GLISSIÈRE

Détachez les 2 parties de la glissière à l'aide du loquet noir



G1 - Partie fixée sur le côté du meuble

G2 - Partie fixée sur la tablette

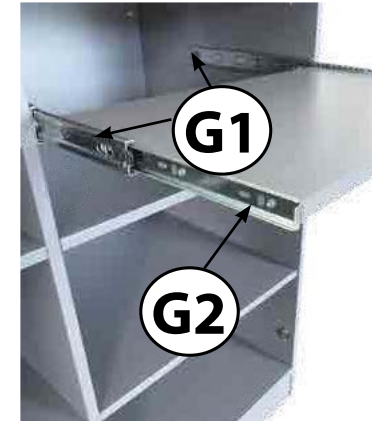

2 PRÉPARATION Pan de travail

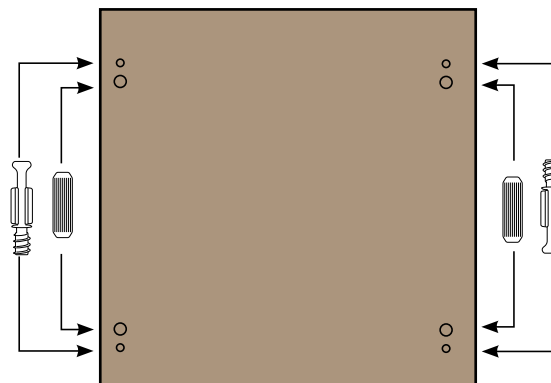

3 PRÉPARATION Fond et étagères

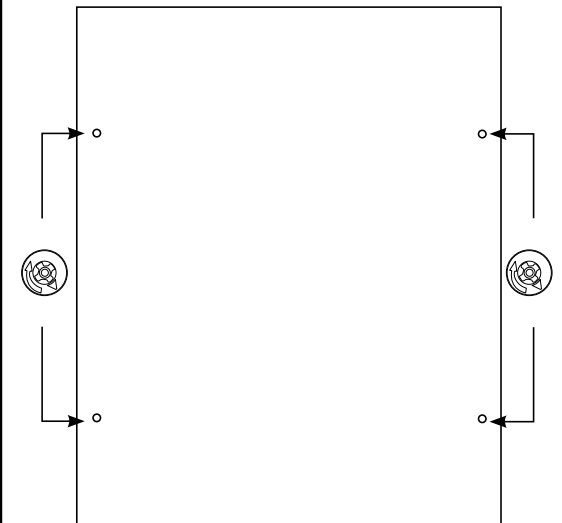

B0005 - MODULE INFORMATIQUE AVEC PORTES



4 ASSEMBLAGE Côtés, plinthe, étagère du bas / Fond

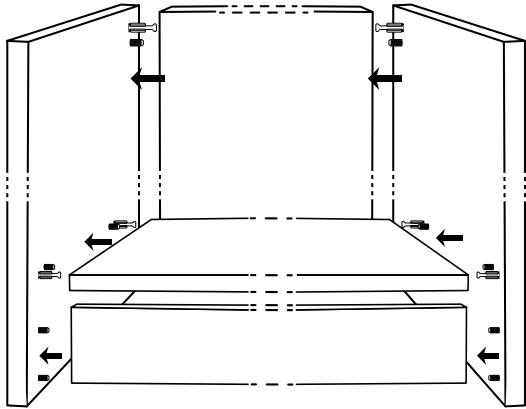

5 ASSEMBLAGE Plan de travail

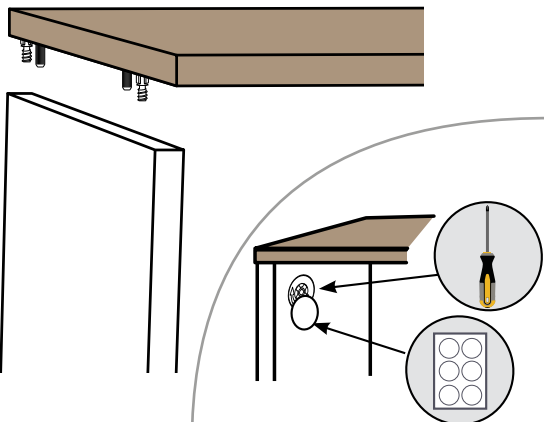

6 Portes

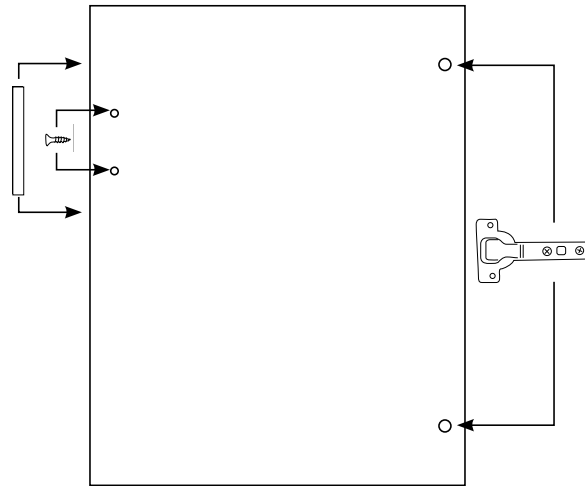

B0006

MODULE INFORMATIQUE AVEC PORTES

REF.	Dimension (HxLxP) en mm
B0006	1120 x 1200 x 600













NOMBRE DE COLIS

Plusieurs colis possibles référencés
comme suit : 1/2 et 2/2 pour 2 colis

CONTENU DES COLIS

- Plan de travail rectangulaire
- Côtés x2 + 1 planche séparation
- Fond x1
- Étagères x6
- Supports coulissants pour clavier x2
- Portes x2
- Plinthe x1
- Glissières x4
- Poignées x2
- Sachet x1

VISSERIE

- | | |
|--|--|
| 
▶ Pied réglable | 
▶ Écrou à vis |
| 
▶ Excentrique | 
▶ Goujon |
| 
▶ Cheville | 
▶ Pastille |
| 
▶ Taquet | 
▶ Cheville métal |
| 
▶ Sachet vis | 
▶ Fixation portes |
| 
▶ Glissière | |

B0006 - MODULE INFORMATIQUE AVEC PORTES



1 PRÉPARATION Côtés

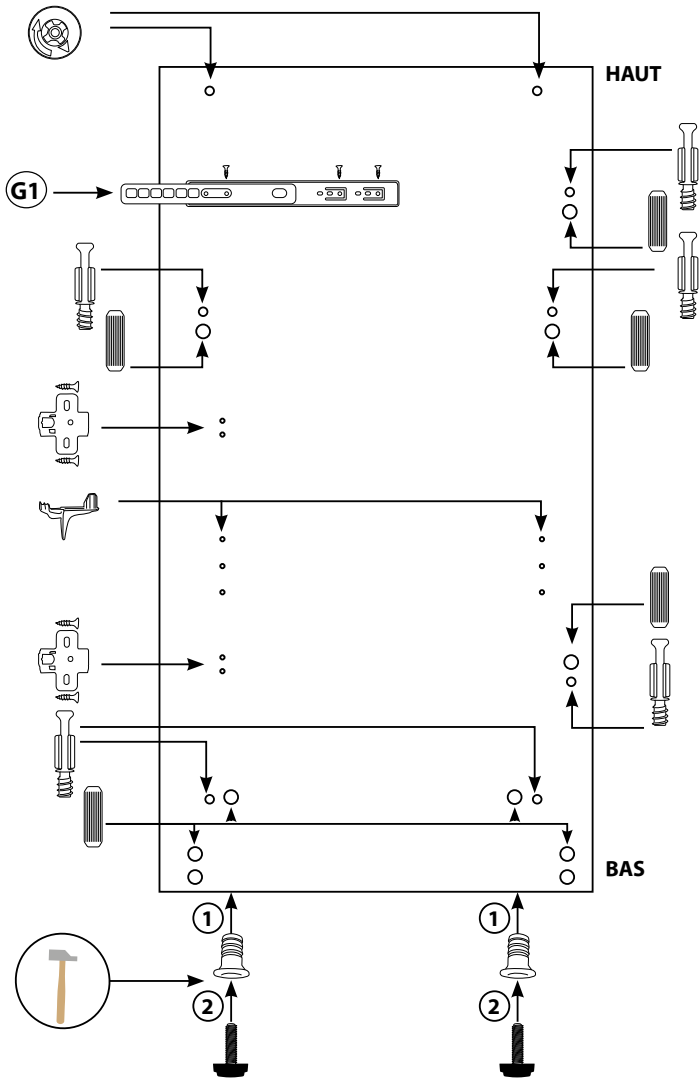

GLISSIÈRE

Détachez les 2 parties de la glissière à l'aide du loquet noir



G1 - Partie fixée sur le côté du meuble

G2 - Partie fixée sur la tablette

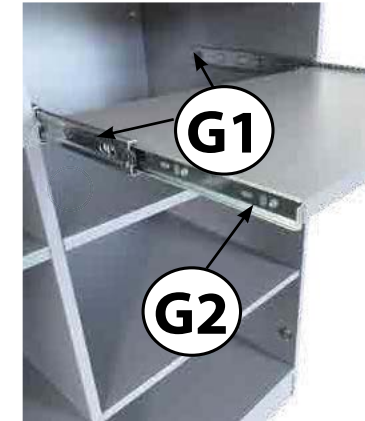

2 PRÉPARATION Fond

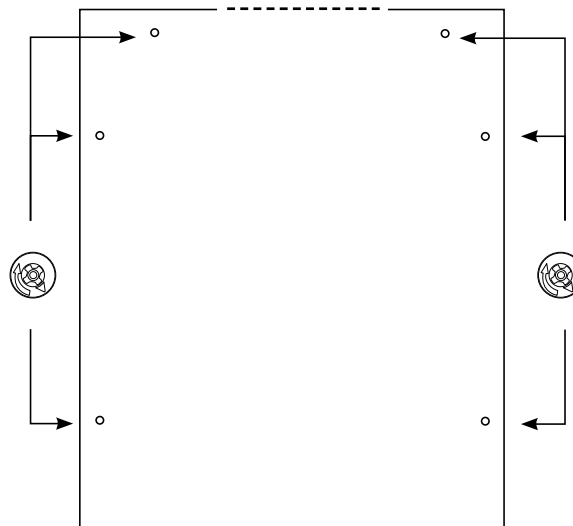

3 ASSEMBLAGE Côtés, plinthe, étagère du bas / Fond

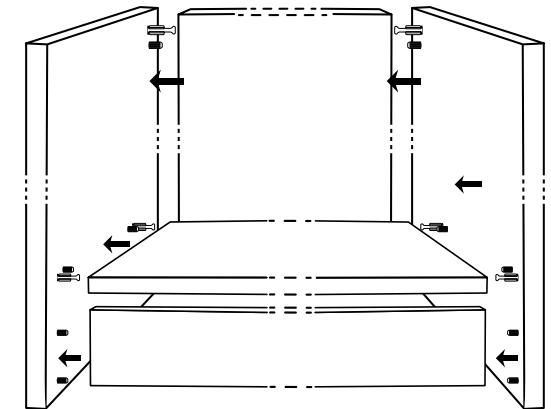

B0006 - MODULE INFORMATIQUE AVEC PORTES



4 PRÉPARATION Tablette de séparation verticale

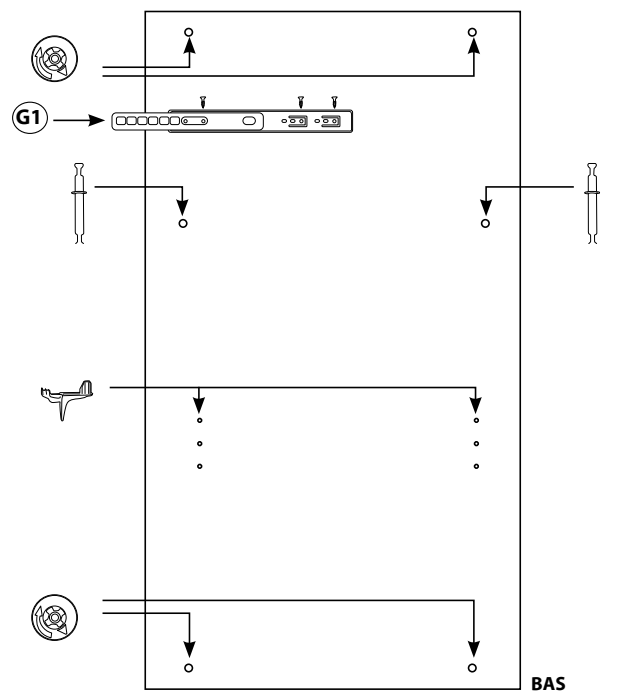

5 ASSEMBLAGE Planche séparation verticale

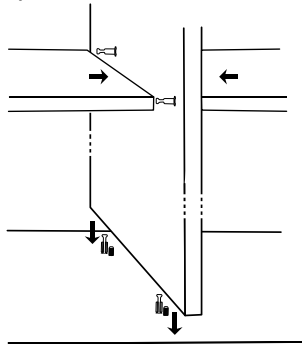

6 PRÉPARATION Pan de travail

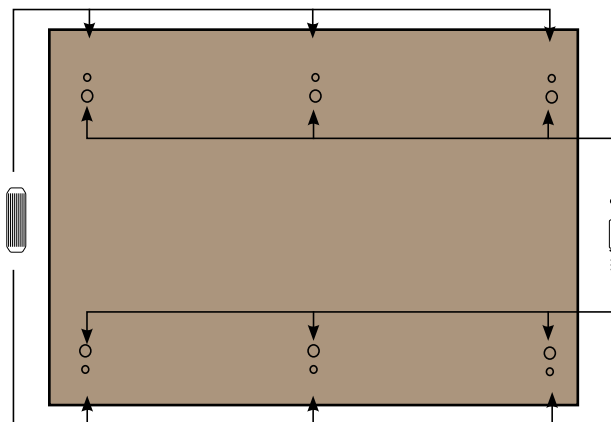

7 ASSEMBLAGE Plan de travail

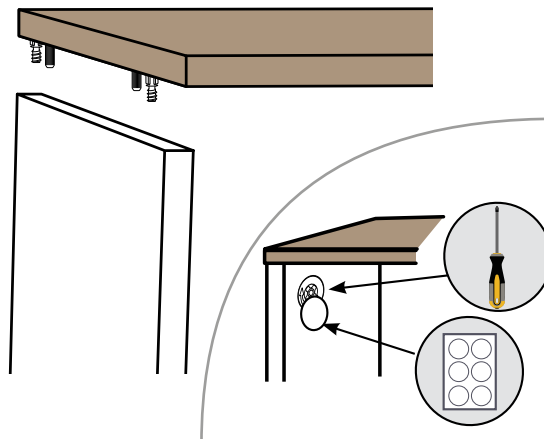

8 Portes

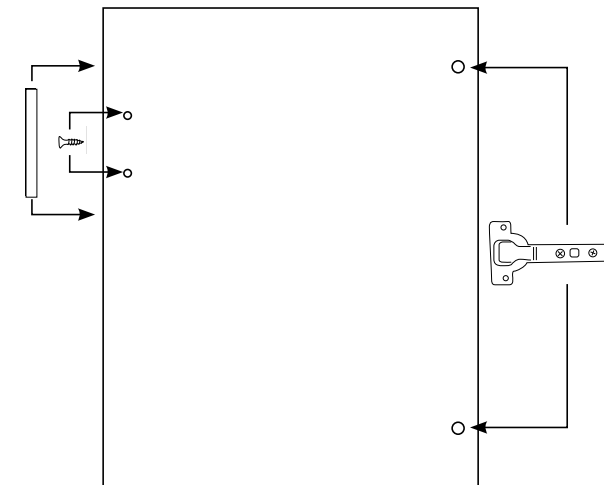

B0031

MODULE PMR - 2 ÉTAGÈRES

REF.	Dimension (HxLxP) en mm
B0031	800 x 800 x 600

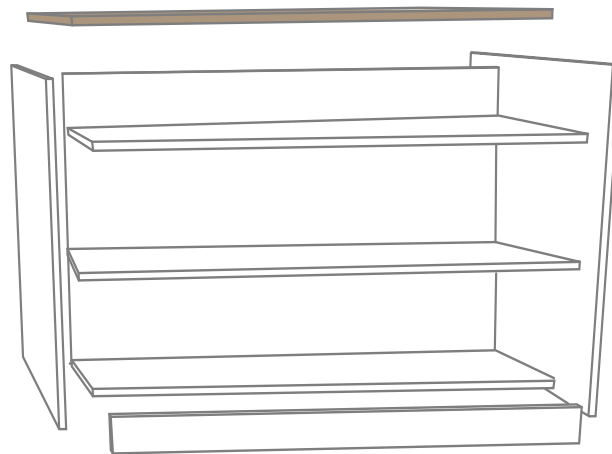

NOMBRE DE COLIS

Plusieurs colis possibles référencés
comme suit : 1/2 et 2/2 pour 2 colis

CONTENU DES COLIS

- Plan de travail rectangulaire x1
- Côtés x2
- Étagères x3
- Plinthe x1
- Fond x1
- Sachet de visserie x1

VISSERIE



► Pied réglable



► Écrou à vis



► Goujon



► Excentrique



► Cheville

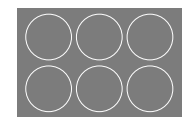

► Pastiche



► Taquet

B0031 - MODULE PMR - 2 ÉTAGÈRES



1 PRÉPARATION Côtés

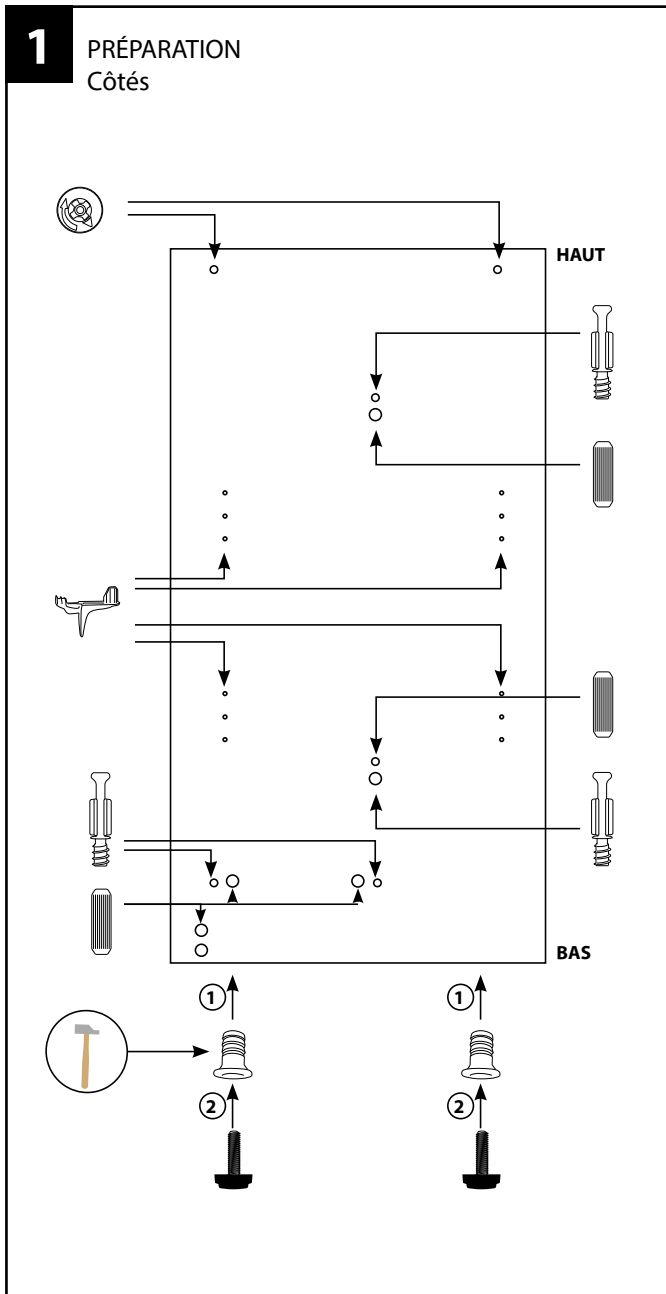

2 PRÉPARATION Pan de travail

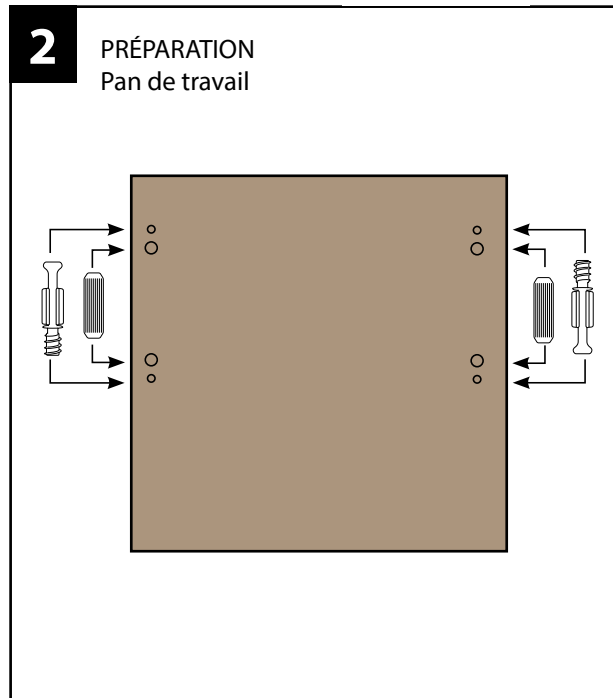

3 PRÉPARATION Fond

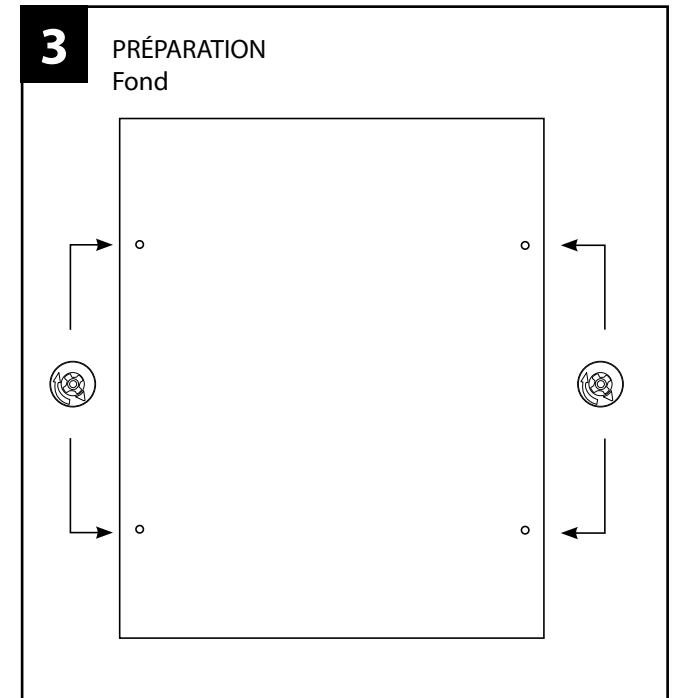

4 ASSEMBLAGE Côtés, plinthe, étagère du bas / Fond

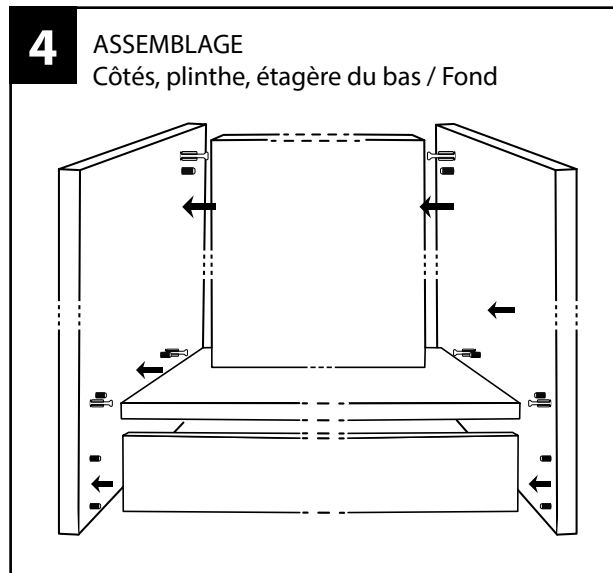

5 ASSEMBLAGE Plan de travail

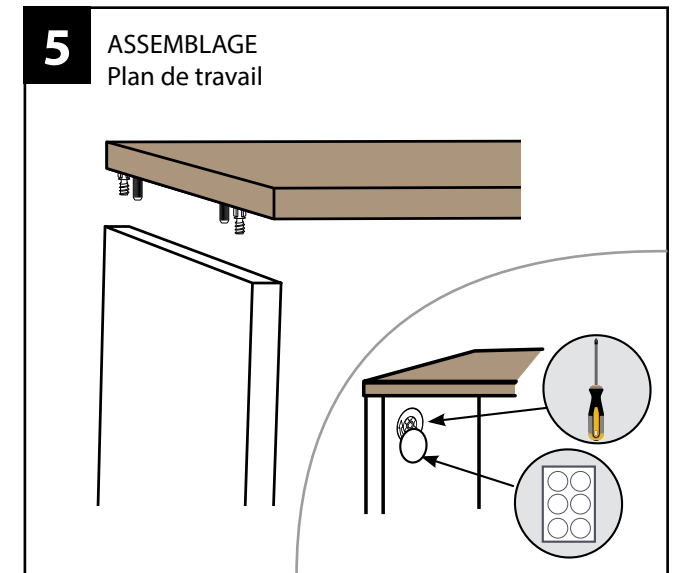

B0030

MODULE PMR - 2 ÉTAGÈRES

REF.	Dimension (HxLxP) en mm
B0030	800 x 1200 x 600

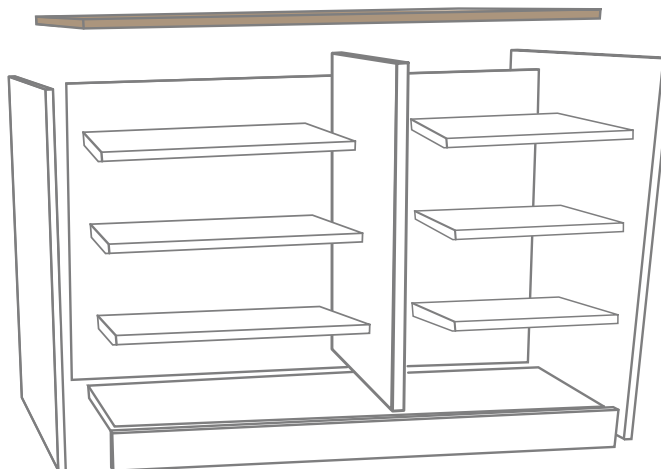

NOMBRE DE COLIS

Plusieurs colis possibles référencés
comme suit : 1/2 et 2/2 pour 2 colis

CONTENU DES COLIS

- Plan de travail rectangulaire x1
- Côtés x2 + planche séparation
- Étagères x3
- Plinthe x1
- Fond x1
- Sachet de visserie x1

VISSERIE



▶ Pied réglable



▶ Écrou à vis



▶ Goujon



▶ Excentrique



▶ Cheville

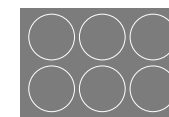

▶ Pastille



▶ Taquet

B0030 - MODULE PMR - 2 ÉTAGÈRES



1 PRÉPARATION Côtés

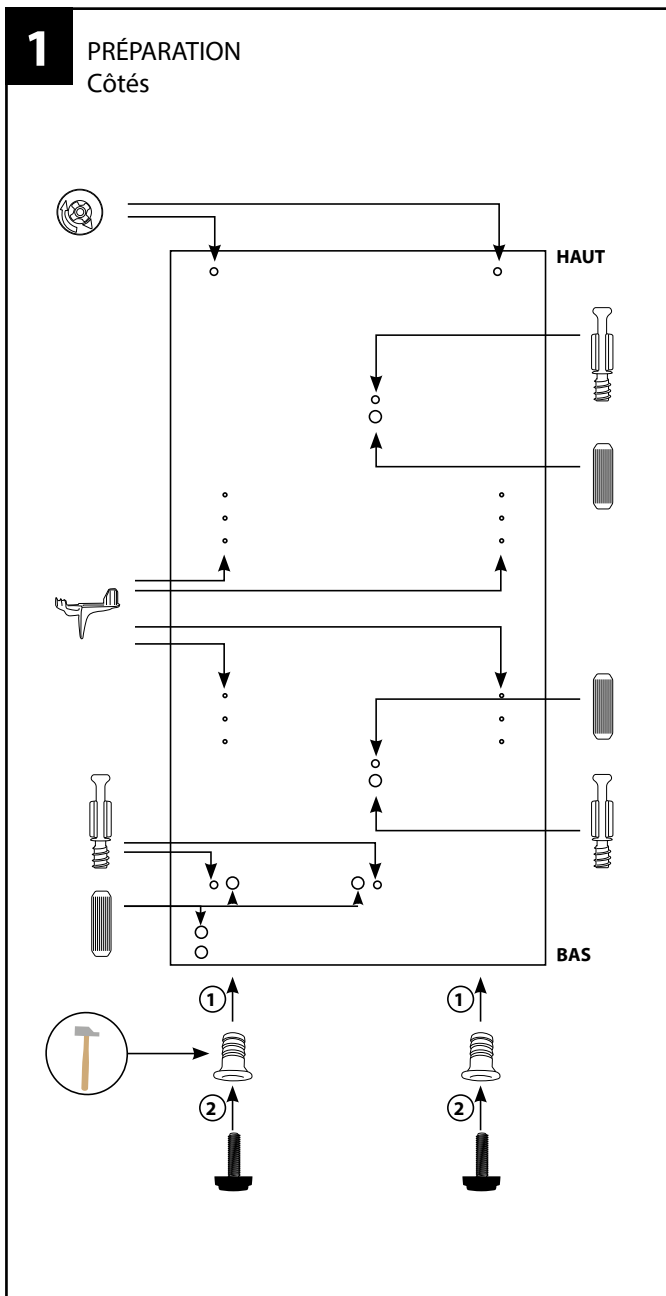

2 PRÉPARATION Pan de travail

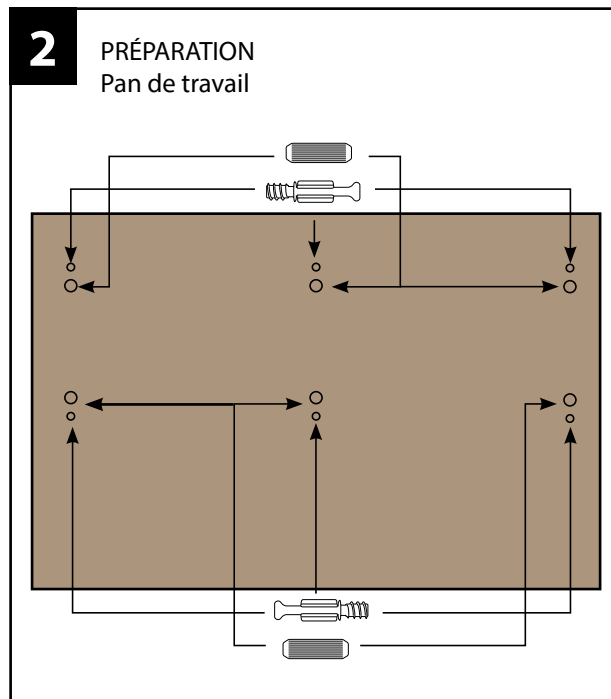

3 PRÉPARATION Fond

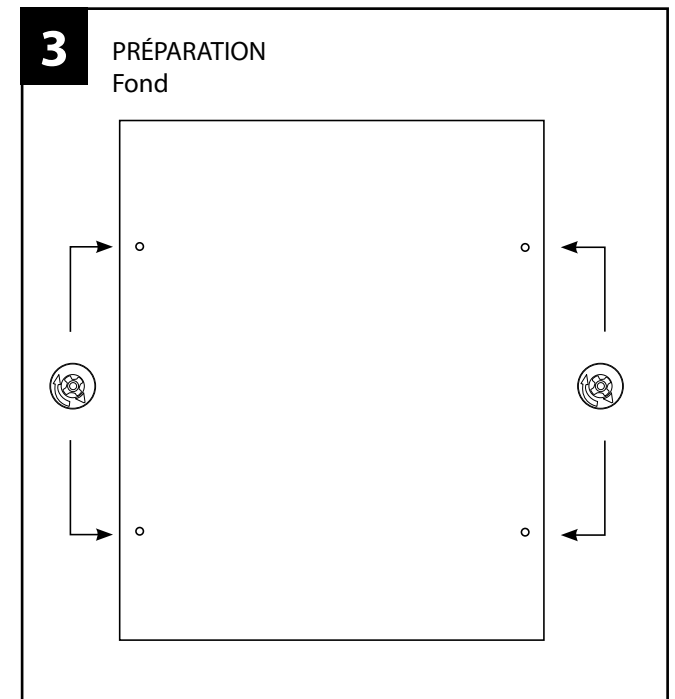

4 ASSEMBLAGE Côtés, plinthe, étagère du bas / Fond

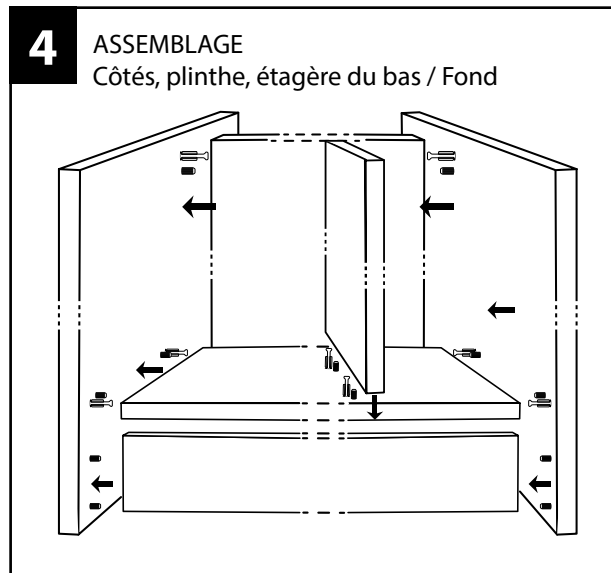

5 ASSEMBLAGE Plan de travail

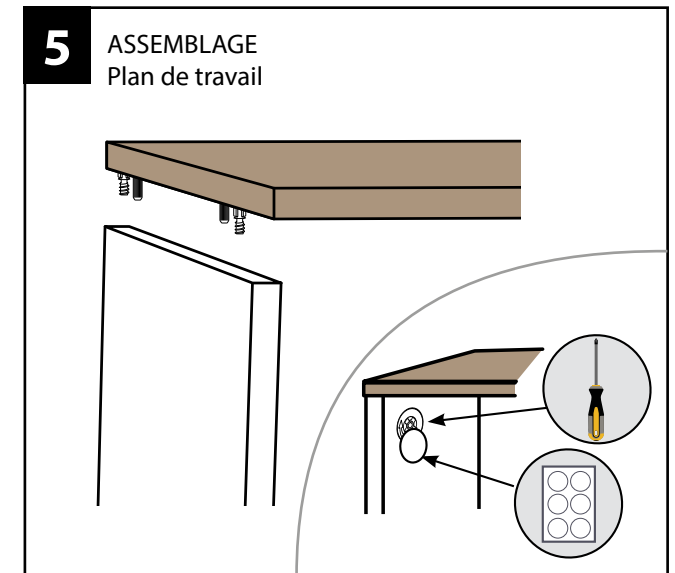

B0008 - B0009

COMPTOIR BUREAU

REF.	Dimension (HxLxP) en mm
B0008	1120 x 800 x 600
B0009	1120 x 600 x 600

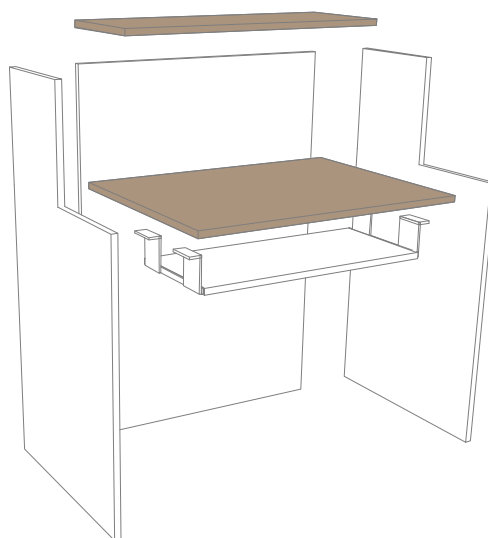

NOMBRE DE COLIS

Plusieurs colis possibles référencés
comme suit : 1/2 et 2/2 pour 2 colis

CONTENU DES COLIS

- Plans de travailx2
- Côtés x2
- Fond x1
- Support coulissant pour clavier x1
- Glissières x2
- Sachet x1

VISSERIE



▶ Pied réglable



▶ Écrou à vis



▶ Excentrique



▶ Goujon



▶ Cheville



▶ Pastiche



▶ Taquet



▶ Sachet vis



▶ Équerre
glissière



▶ Glissière

B0008 - B0009 -COMPTOIR BUREAU



1 PRÉPARATION Côtés

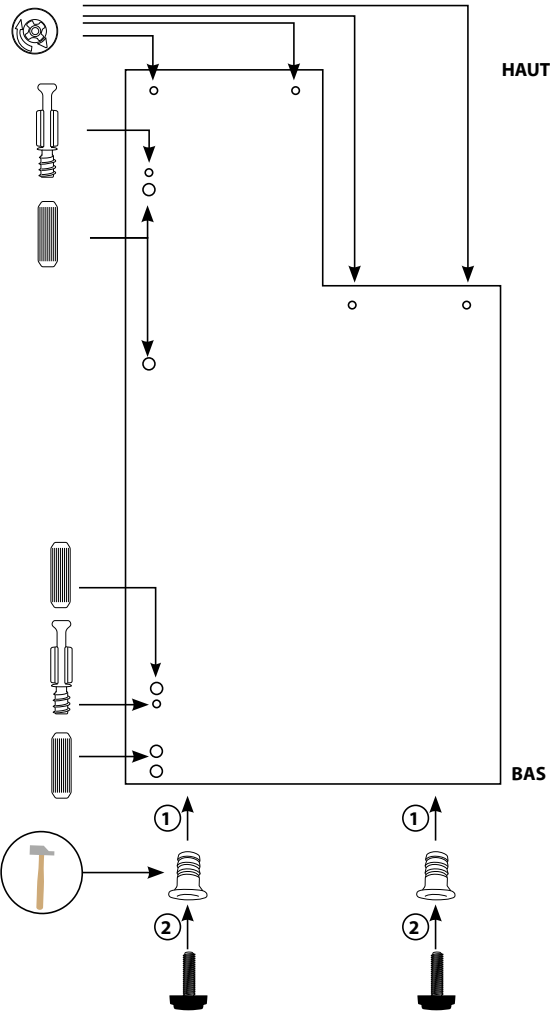

2 PRÉPARATION Pan de travail comptoir

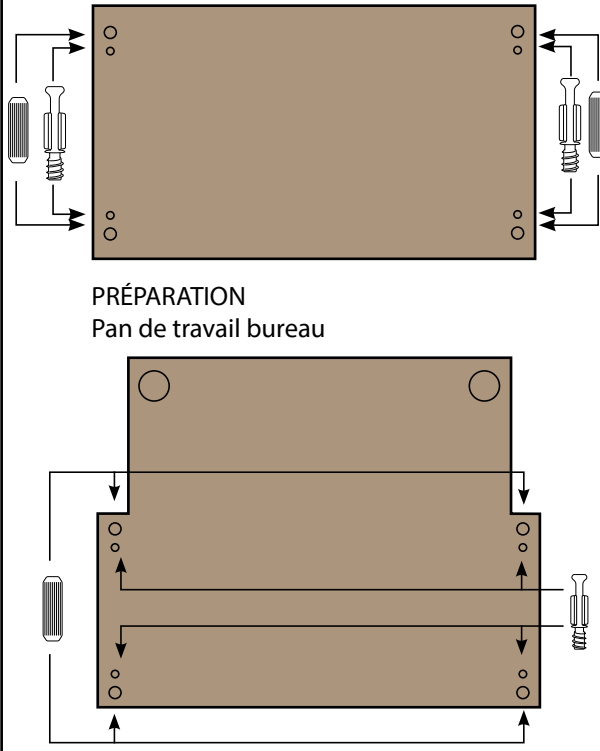

3 PRÉPARATION Fond

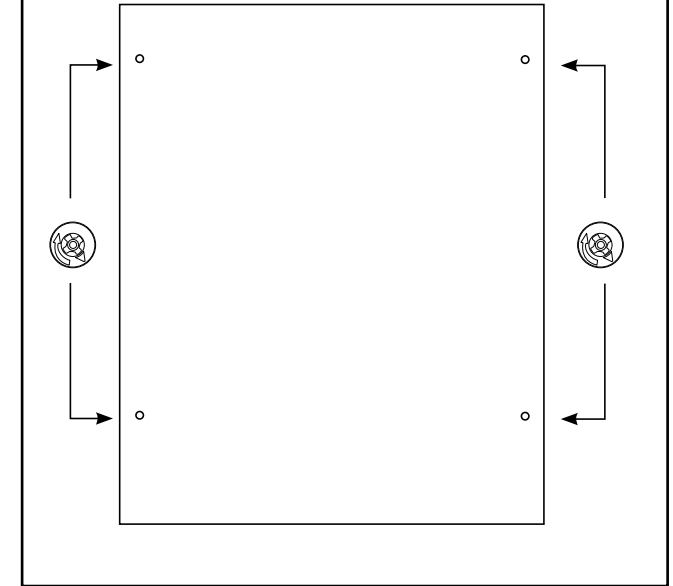

GLISSIÈRE

Fixez la glissière sur la tablette informatique



Fixer l'équerre sur la glissière en choisissant la hauteur.

Fixer l'ensemble sur le meuble.



B0007

COMPTOIR BUREAU

REF.	Dimension (HxLxP) en mm
B0007	1120 x 1200 x 600

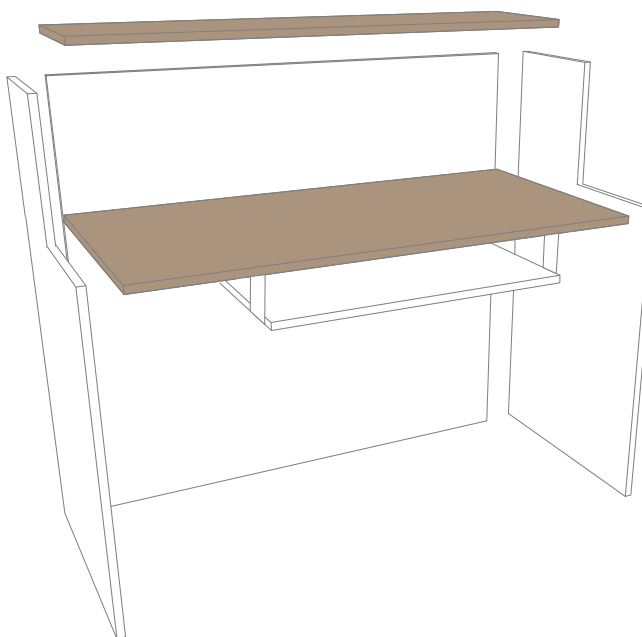

NOMBRE DE COLIS

Plusieurs colis possibles référencés
comme suit : 1/2 et 2/2 pour 2 colis

CONTENU DES COLIS

- Plans de travailx2
- Côtés x2
- Fond x1
- Support coulissant pour clavier x1
- Petits côtés support coulissant x2
- Glissières x2
- Sachet x1

VISSERIE



▶ Pied réglable



▶ Écrou à vis



▶ Excentrique



▶ Goujon



▶ Cheville



▶ Pastille



▶ Taquet



▶ Sachet vis



▶ Équerre
glissière



▶ Glissière

B0007 - COMPTOIR BUREAU

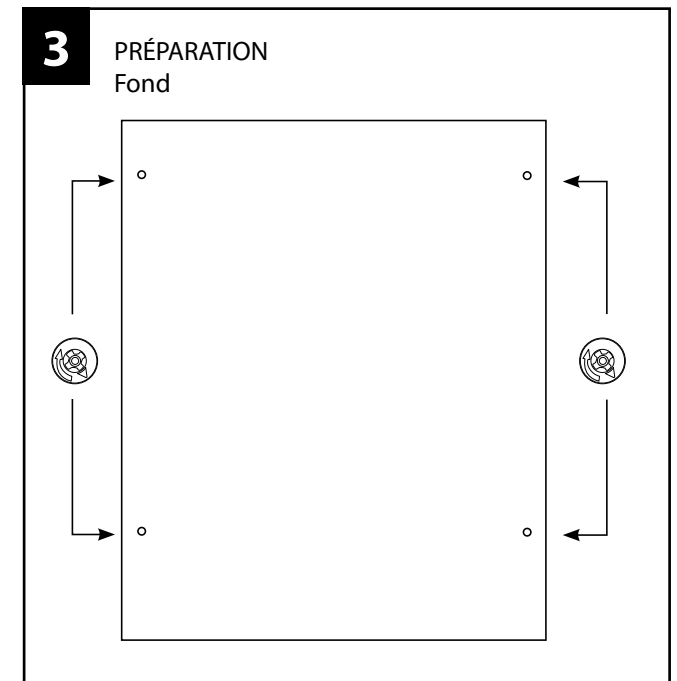
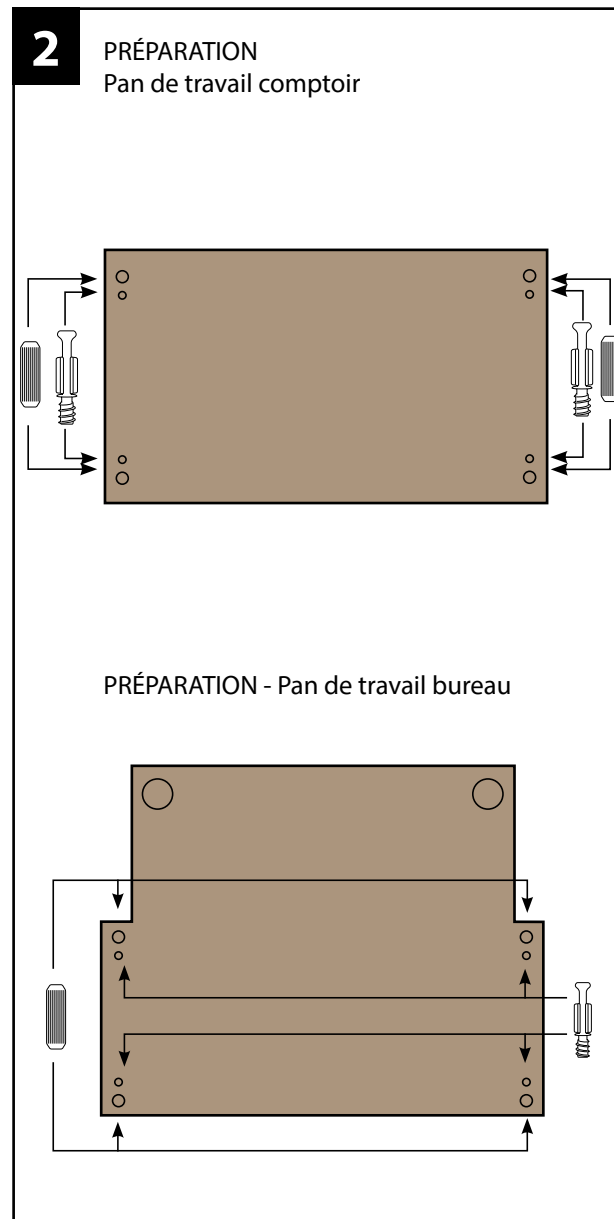
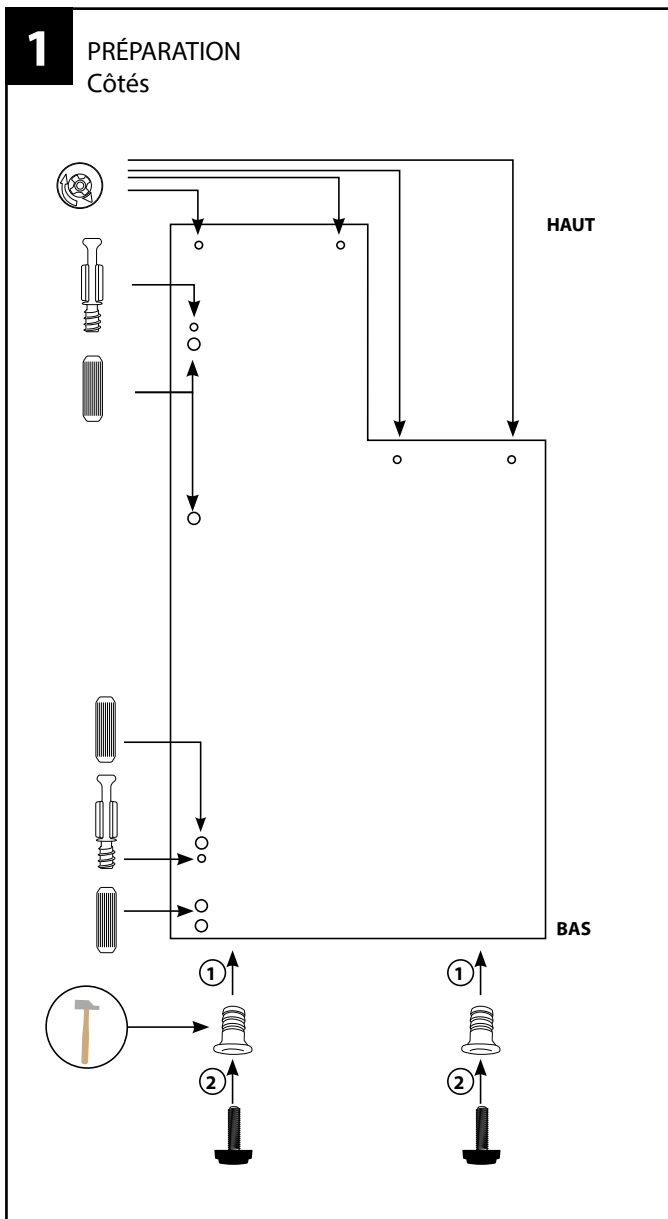

B0007 - COMPTOIR BUREAU



4 ASSEMBLAGE Côtés, plinthe, étagère du bas / Fond

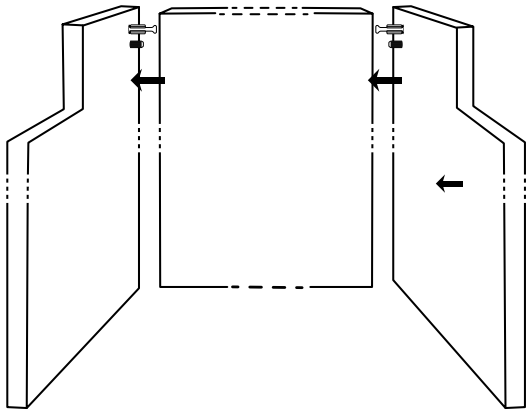

5 ASSEMBLAGE Plans de travail

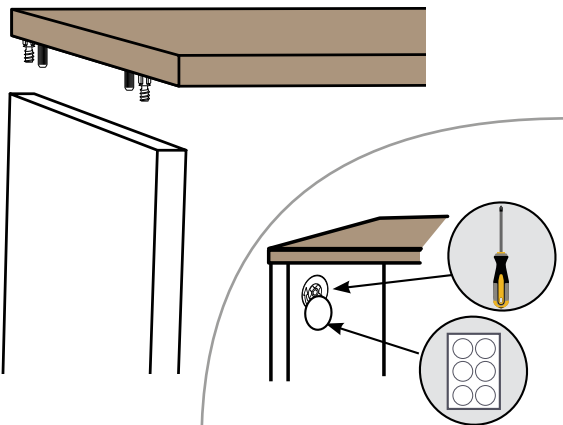

GLISSIÈRE

Fixez la glissière sur la tablette informatique



Fixer l'équerre sur la glissière en choisissant la hauteur.

Fixer l'ensemble sur le meuble.



B0011 - B0023 - B0024

COMPTOIR ET RANGEMENT

REF.	Dimension (HxLxP) en mm
B0011	1120 x 600 x 600
B0024	1120 x 800 x 600
B0023	1120 x 1000 x 600

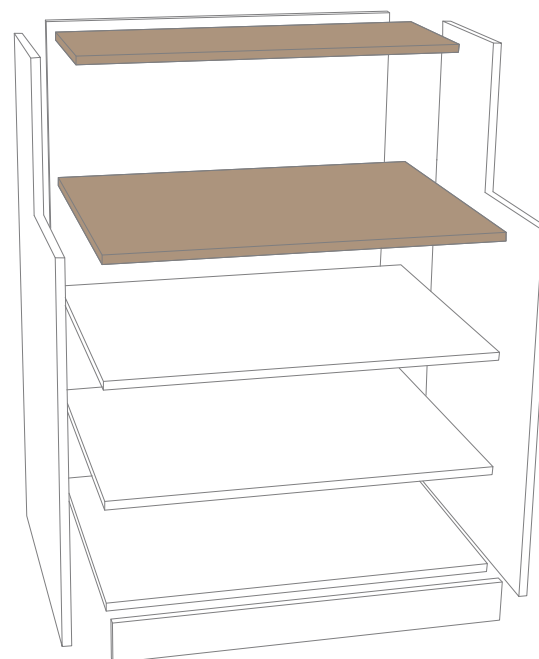

NOMBRE DE COLIS

Plusieurs colis possibles référencés comme suit : 1/2 et 2/2 pour 2 colis

CONTENU DES COLIS

- Plans de travailx2
- Côtés x2
- Fond x1
- Plinthe x1
- Étagères x3

VISSERIE

- ▶  Pied réglable
- ▶  Écrou à vis
- ▶  Excentrique
- ▶  Goujon
- ▶  Cheville
- ▶  Pastille
- ▶  Taquet

B0011 - B0023 - B0024 - COMPTOIR RANGEMENT



1 PRÉPARATION
Côtés

HAUT

BAS

①

②

2 PRÉPARATION - Pan de travail comptoir

PRÉPARATION - Pan de travail bureau

4 ASSEMBLAGE
Côtés, plinthe, étagère du bas / Fond

3 PRÉPARATION
Fond

5 ASSEMBLAGE
Plan de travail

B0010

COMPTOIR ET RANGEMENT

REF.	Dimension (HxLxP) en mm
B0010	1120 x 1200 x 600

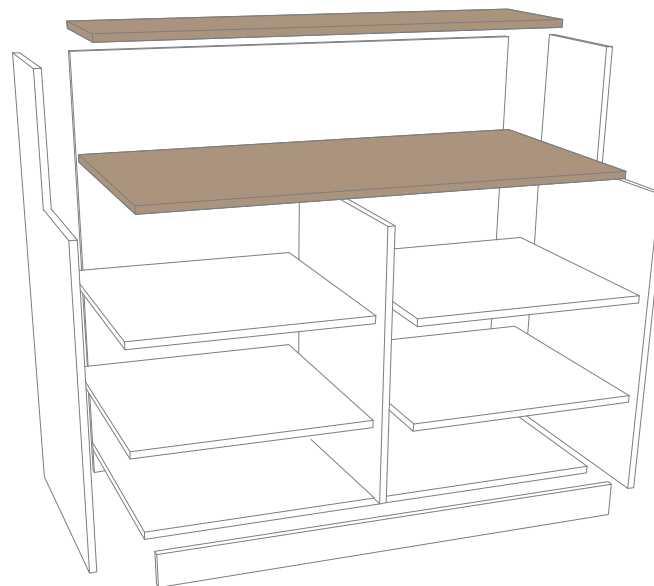

NOMBRE DE COLIS

Plusieurs colis possibles référencés
comme suit : 1/2 et 2/2 pour 2 colis

CONTENU DES COLIS

- Plans de travailx2
- Côtés x2
- Fond x1
- Plinthe x1
- Petites étagères x4
- Grande étagère x1

VISSERIE



▶ Pied réglable



▶ Écrou à vis



▶ Excentrique



▶ Goujon



▶ Cheville



▶ Pastille



▶ Taquet

B00010 - COMPTOIR RANGEMENT



1 PRÉPARATION Côtés

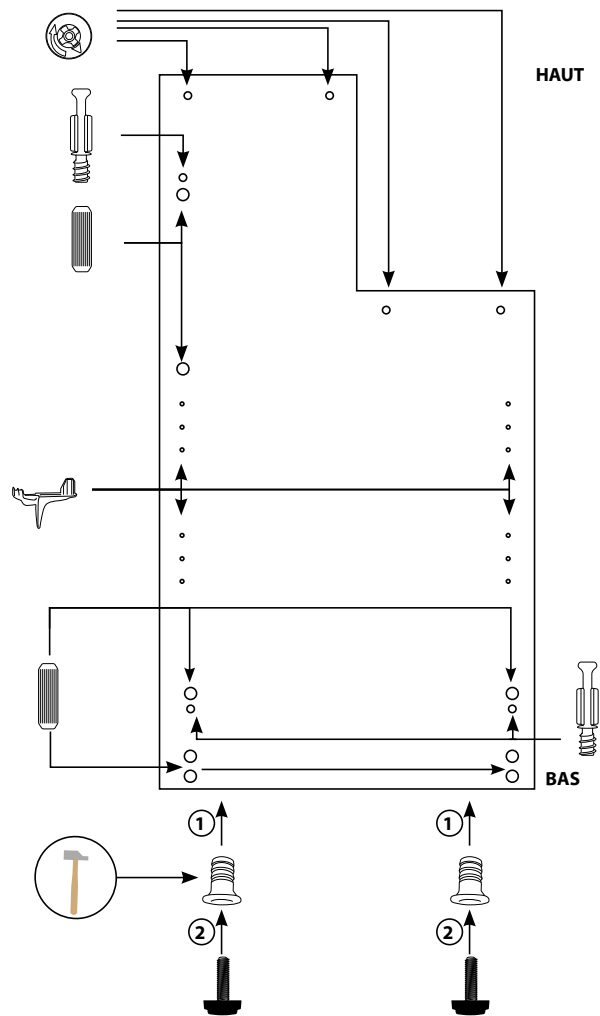

2 PRÉPARATION - Pan de travail comptoir



PRÉPARATION - Pan de travail bureau

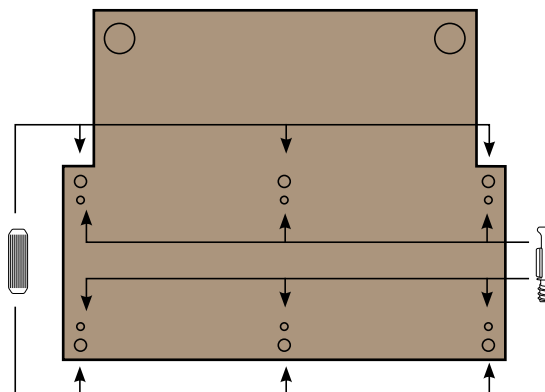

3 PRÉPARATION Fond

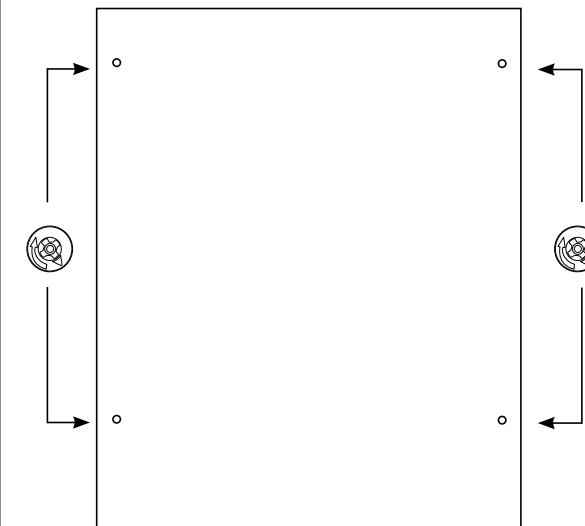

4 ASSEMBLAGE Côtés, plinthe, étagère du bas / Fond

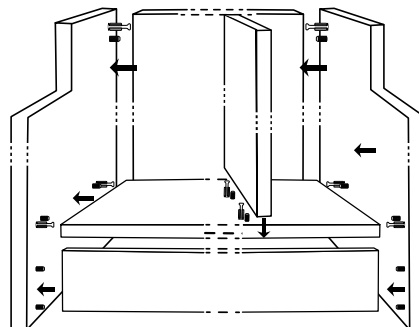

5 ASSEMBLAGE Plan de travail

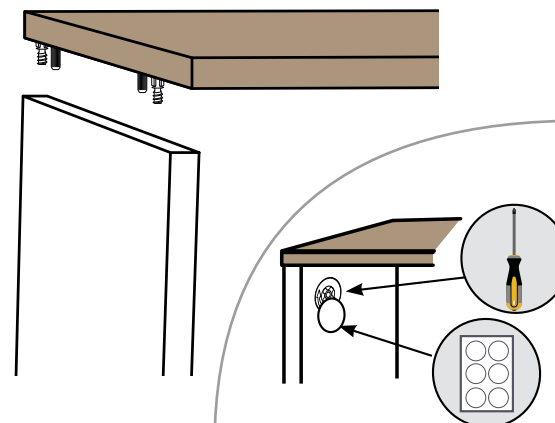

B0015

MODULE INFORMATIQUE ET RANGEMENT

REF.	Dimension (HxLxP) en mm
B0015	1120 x 1000 x 600



NOMBRE DE COLIS

Plusieurs colis possibles référencés
comme suit : 1/2 et 2/2 pour 2 colis

CONTENU DES COLIS

- Plan de travail rectangulaire x1
- Côtés x2 + planche séparationx1
- Grande étagère x1
- Petites étagères x2
- Support coulissant pour clavier x1
- Plinthe x1
- Fond x1
- Sachet de visserie x1

VISSERIE



▶ Pied réglable



▶ Écrou à vis



▶ Goujon



▶ Excentrique



▶ Cheville

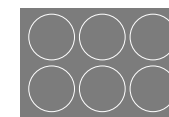

▶ Pastille



▶ Taquet



▶ Glissière

B0015 - MODULE INFORMATIQUE ET RANGEMENT

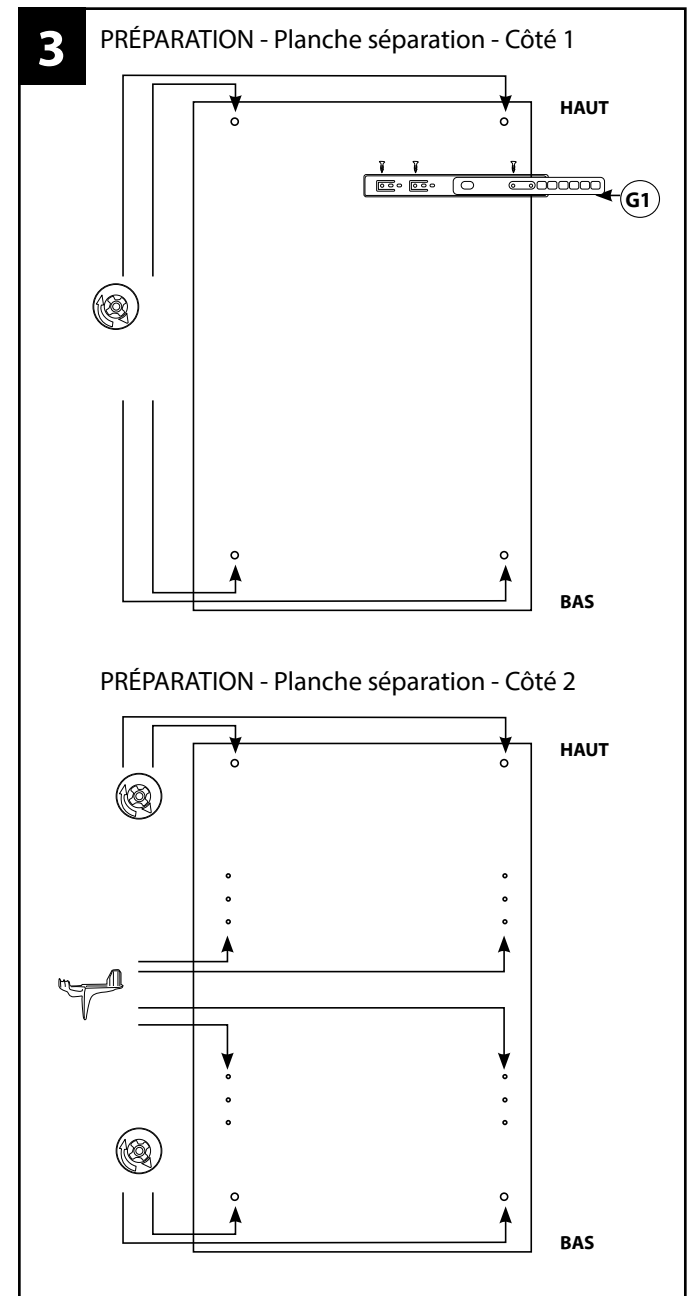
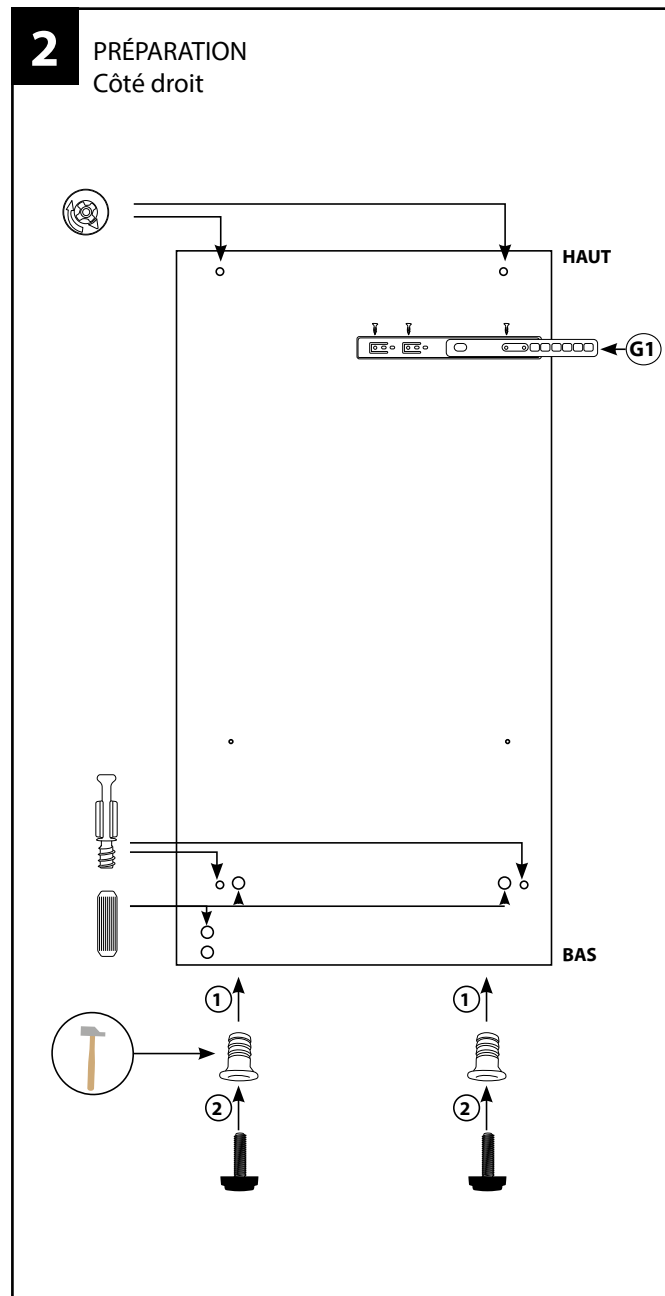
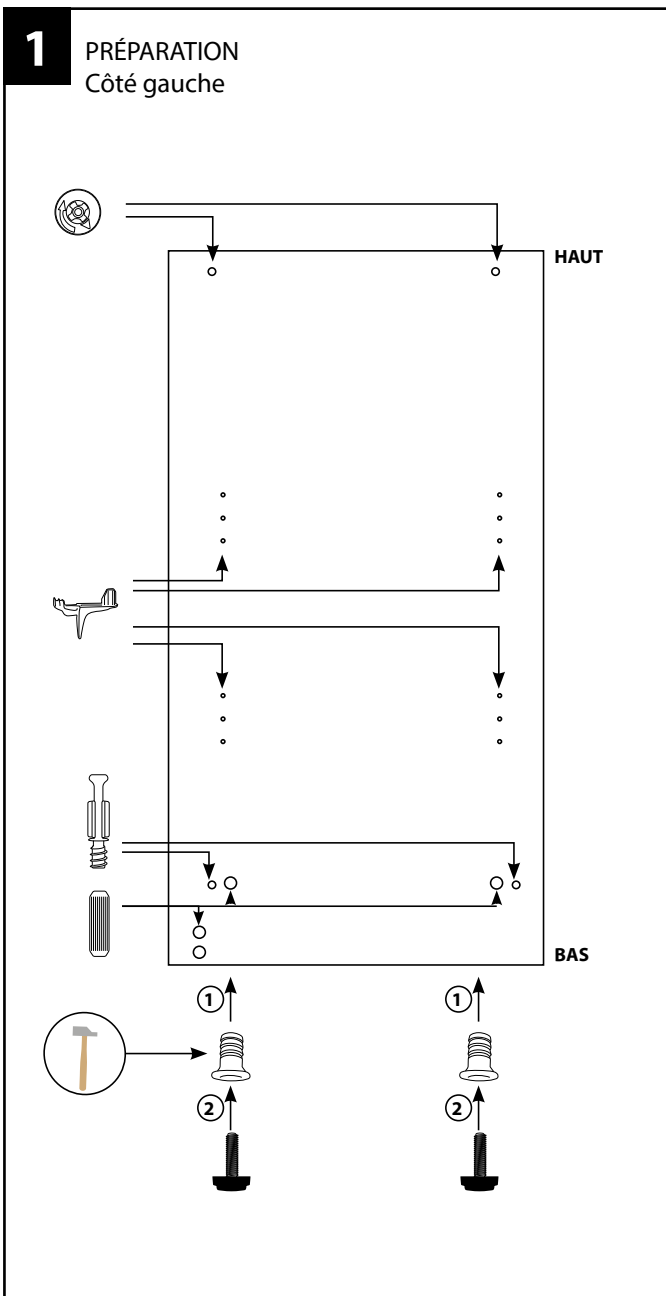

B0015 - MODULE INFORMATIQUE ET RANGEMENT

GLISSIÈRE

Détachez les 2 parties de la glissière à l'aide du loquet noir



G1 - Partie fixée sur le côté du meuble



G2 - Partie fixée sur la tablette

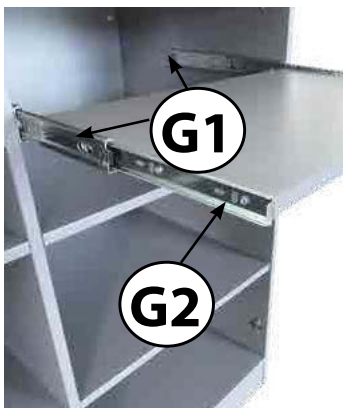

4

PRÉPARATION
Pan de travail

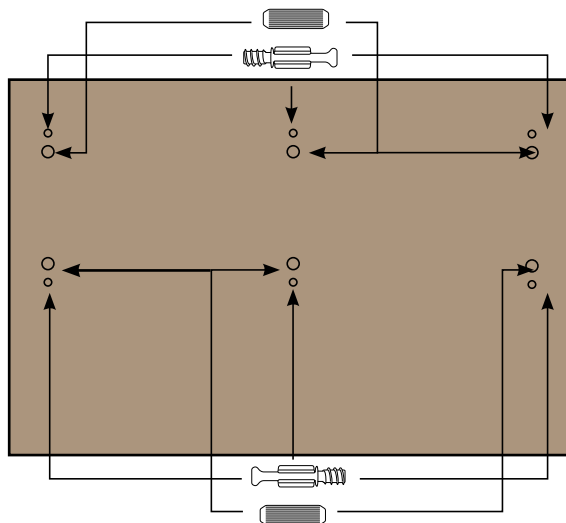

5

PRÉPARATION
Fond

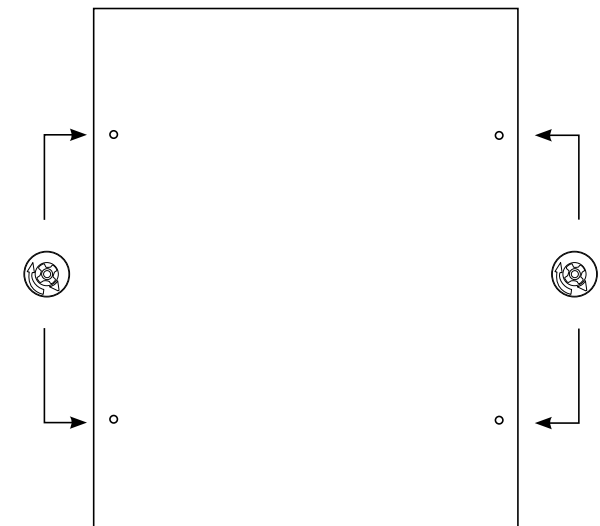

6

ASSEMBLAGE
Côtés, plinthe, étagère du bas / Fond

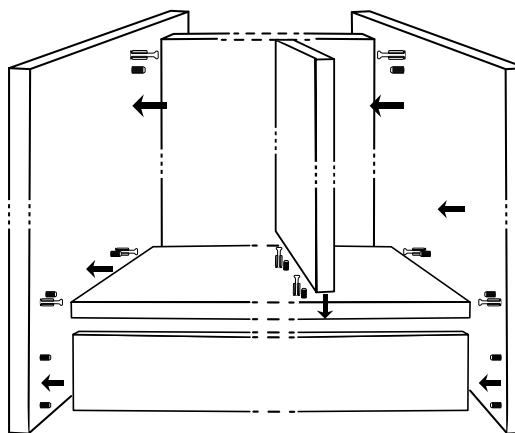

7

ASSEMBLAGE
Plan de travail

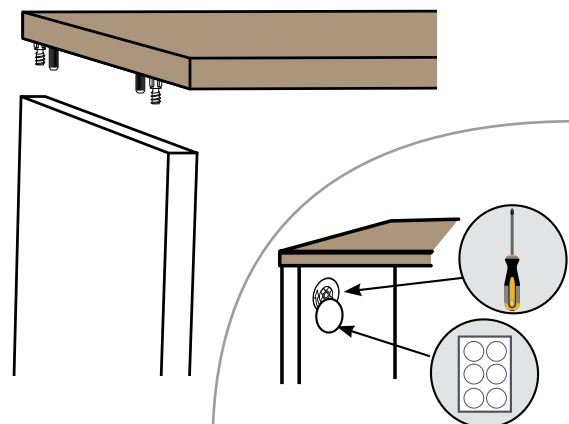

B0026-B0059

PORTILLON BOIS

REF.	Dimension (HxL) en mm			Nbr de charnières
B0059	980	x	600	3
B0026	580	x	600	2

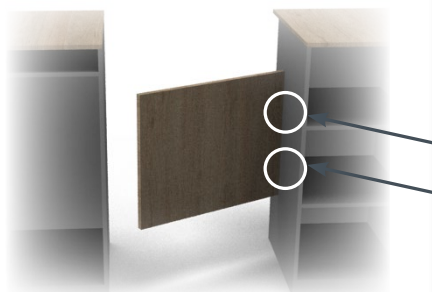

VISSERIE



▶ Vis 35 mm pour portes



▶ Vis 30 mm pour meuble



▶ Douilles de compensation



▶ Charnière double-action (type western)



▶ Tige et picots de réglage



B0026 - B0059 - Portillons

1 FIXATION DES CHARNIÈRES SUR LE PORTILLON

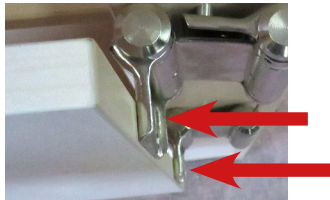
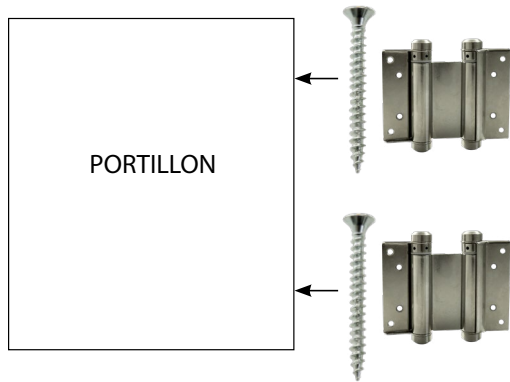

2 FIXATION DES CHARNIÈRES SUR LE MEUBLE

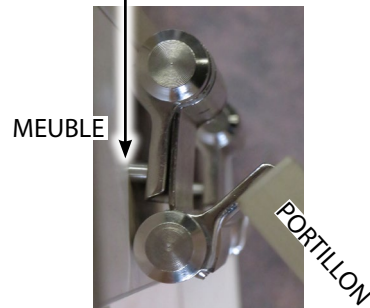
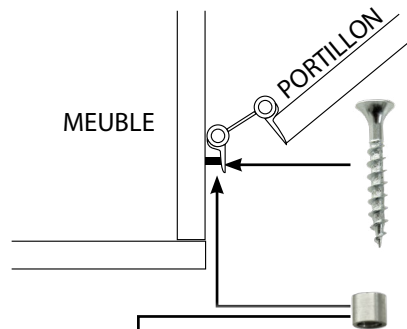

3 RÉGLAGE DU PORTILLON



Tourner à l'aide de la tige

①



②

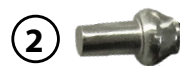

Insérer le picot pour figer le réglage